

# Safe vaccine handling, cold chain and immunizations

A manual for the Newly Independent States



**GLOBAL PROGRAMME FOR VACCINES AND IMMUNIZATION**  
**EXPANDED PROGRAMME ON IMMUNIZATION**



*World Health Organization, Geneva, 1998*

*Produced in collaboration with Basics, USAID and UNICEF*

---

Based on the “Cold Chain Training Manual for Health Workers” prepared in Bishkek, Kyrgyzstan in 1992/93 by health officials and staff, with the assistance of the USAID/REACH Project, incorporating original materials from WHO and additional materials from UNICEF and USAID/BASICS.

Thanks to all of the WHO, UNICEF, and USAID/BASICS staff and consultants who gave their time, hard work, and expertise in the development of this manual. Special thanks to the Ministries of Health in Kazakhstan, Kyrgyzstan, Moldova, Tajikistan, Turkmenistan, and Uzbekistan, as well as the WHO Steering Committee representatives, for their cooperation, dedication, and support in reviewing, finalizing and field testing this manual.

Through the cooperation of the staff and counterparts of the Ministries of Health and their affiliates, WHO, UNICEF, and the USAID/BASICS project have been active in their technical support to improve and strengthen the immunization programmes and cold chain systems in the NIS. Thanks to WHO for their collaboration and guidance with the government and the Ministries of Health in the development of immunization policy, funds in support of vaccine prophylaxis, training of specialists and support for national immunization programs. Thanks to UNICEF for its work with the governments of the NIS in the procurement of vaccines from WHO pre-qualified manufacturers and in procurement of equipment such as cold rooms, cold boxes, refrigerators and freezers to upgrade the cold chain systems. Thanks to USAID/BASICS for their assistance with the Ministries of Health in immunization policy development and reform, assessments and trainings in cold chain logistics and management, and immunization system strengthening.

---

# Table of contents

<b>Preface</b> .....	<b>v</b>
<b>1. Immunity and vaccines</b> .....	<b>1</b>
1.1 Immunity .....	1
1.2 Target diseases .....	1
1.3 How are vaccines made? .....	2
1.4 Vaccine stability .....	2
1.5 Correct administration of vaccines .....	3
1.6 Policy on use of opened vials of vaccine .....	6
<b>2. The cold chain system</b> .....	<b>8</b>
2.1 Vaccine storage .....	9
2.2 Vaccine potency .....	11
2.3 Vaccine stock quantities .....	11
2.4 Vaccine stock records .....	14
2.5 Vaccine arrival report .....	15
<b>3. Cold chain equipment and its use</b> .....	<b>16</b>
3.1 Equipment for vaccine transportation .....	17
3.2 Equipment for vaccine storage .....	24
<b>4. Maintenance of cold chain equipment</b> .....	<b>36</b>
4.1 Installation .....	36
4.2 Defrosting .....	37
4.3 Cleaning .....	37
4.4 Safety requirements .....	38
<b>5. Control and monitoring of temperatures</b> .....	<b>39</b>
5.1 Thermometers .....	39
5.2 Temperature record sheets .....	40
5.3 Refrigerator or freezer thermostats .....	40
5.4 Cold chain monitor card .....	41
5.5 Vaccine vial monitor .....	44
5.6 DT & TT vaccine shipping indicators .....	47
5.7 FreezeWatch indicator .....	48
5.8 Stop!Watch indicator .....	48
5.9 Vaccine shake test .....	49
<b>6. The cold chain during immunization sessions</b> .....	<b>3</b>
6.1 At the beginning of the working day .....	3
6.2 During immunization sessions at fixed health facilities .....	3
6.3 At the end of the working day .....	4
6.4 During outreach immunization sessions .....	5

---

<b>7. Syringes, needles and sterilisation.....</b>	<b>6</b>
7.1 Injection equipment.....	6
7.2 Sterility and sterilisation of reusable equipment.....	8
7.3 Confirming complete sterilization.....	9
<b>8. Breakdowns and emergencies.....</b>	<b>4</b>
8.1 Technical faults in the refrigerator.....	4
8.2 Plan for cold chain emergencies.....	7
<b>Annex 1: Vial size and doses/vial for EPI vaccines.....</b>	<b>11</b>
<b>Annex 2: Vaccine stock record.....</b>	<b>12</b>
<b>Annex 3: Vaccine arrival report.....</b>	<b>13</b>
<b>Annex 4A: Monthly temperature recording sheet (sample).....</b>	<b>15</b>
<b>Annex 4B: Annual temperature recording sheet (sample).....</b>	<b>16</b>
<b>Annex 5A: Adverse events following immunization.....</b>	<b>17</b>
<b>Annex 5B: AEFI case-investigation report form.....</b>	<b>18</b>
<b>Annex 6: National immunization days and mass campaigns.....</b>	<b>20</b>
<b>Annex 7: Sample refrigerator/ cold chain check list.....</b>	<b>21</b>
<b>Annex 8: List of related documents available in Russian (as of December 1997).....</b>	<b>22</b>

---

# Preface

This is a revised and updated version of an earlier document entitled “Cold Chain Training Manual for Health Workers” which was prepared in Bishkek, Kyrgyzstan in 1992/93 with the assistance of the USAID/REACH Project. Since publication, that manual has been field tested and used for training and reference purposes throughout the Newly Independent States (NIS) and in other regions, and has proven to be an important document for all staff involved in EPI planning and implementation. In the period since the original version was issued, many new developments have occurred in the field of immunization, and new strategies and technologies have been introduced. This new manual reflects these changes, and incorporates all updated information. It also includes additional content on sterilization, safe handling and disposal of syringes, and safe administration of vaccines.

Much of the content and concept of the original manual, and this new version, reflects information, policy and documentation from the WHO Global Programme on Vaccines/Expanded Programme on Immunization (EPI). Apart from specific references in the text to individual WHO documents, Annex 8 provides a list of all the main related documents and training materials for EPI available in Russian from WHO and other sources as of September 1997.

As with the original manual, this version is written for personnel who are directly responsible for the storage and handling of vaccines at all levels of the health system. It is also intended for use by supervisors/managers at individual health facilities where vaccine is handled and immunizations are given, including district (rayon) and regional (oblast) levels.



---

# 1. Immunity and vaccines

## 1.1 Immunity

If you have had measles you will never contract this disease again, since your body has acquired immunity to measles. Whenever you contract some infection your body starts developing antibodies to the virus or bacteria. These antibodies kill the microorganisms and afterwards remain in the body to prevent recurrence of the disease.

During the first months of life, an infant is protected against many infections by antibodies acquired from the mother before its birth. The infant will retain these maternal antibodies for several months, but normally by the time the child reaches 1 year of age, antibodies acquired from the mother are no longer effective. The infant starts developing antibodies on its own, either following natural contact with a virus or bacteria or after immunization.

## 1.2 Target diseases

There are many infectious diseases that can result in the death or disability of infants and young children. Some of the most dangerous of these are:

- poliomyelitis
- measles
- diphtheria
- whooping cough
- tetanus
- tuberculosis
- hepatitis B
- mumps

These diseases have one thing in common - they can all be prevented by immunization. Immunization is achieved by the administration of a vaccine, produced from an attenuated, inactivated or killed form of the virus or bacteria. A vaccine is normally injected, or in some cases may be given orally. The vaccine will provoke the development of antibodies in the infant, who thus acquires immunity without suffering the disease.

The Expanded Programme on Immunization (EPI) is a global initiative of the World Health Organization (WHO), whose objective is to immunize all children worldwide against 7 of the most serious diseases listed above. WHO is joined by many other national and international agencies in this effort, and already much progress has been made to ensure that all the world's children are protected against these target childhood diseases. Most national health authorities also have their own programmes of immunization for infants and young children, and many include the WHO target diseases, sometimes together with others, as their national programme objectives.

---

### 1.3 How are vaccines made?

Vaccines are produced from the same microorganisms or toxins that cause disease, but in either case are modified so as to be harmless to humans. Three main substances are used for the production of vaccines:

- LIVE microorganisms, e.g., weakened measles and polio viruses or tuberculosis bacteria;
- KILLED microorganisms, e.g., pertussis microorganisms used in DPT production; and
- TOXOIDS, e.g., inactivated toxins such as tetanus toxoid and diphtheria toxoid.

In addition, some vaccines are produced using genetic engineering technologies, e.g. recombinant DNA Hepatitis B vaccine.

### 1.4 Vaccine stability

All vaccines are sensitive biological substances that progressively lose their potency (i.e., their ability to give protection against disease). This loss of potency is much faster when the vaccine is exposed to temperatures outside the recommended storage range. Once vaccine potency has been lost, returning the vaccine to correct storage condition cannot restore it. Any loss of potency is permanent and irreversible. Thus, storage of vaccines at the correct recommended temperature conditions is vitally important in order that full vaccine potency is retained up to the moment of administration. Although all vaccines are heat-sensitive, some are far more sensitive than others are. Those listed in Section 1.2 can be arranged in order of decreasing sensitivity to heat as follows:

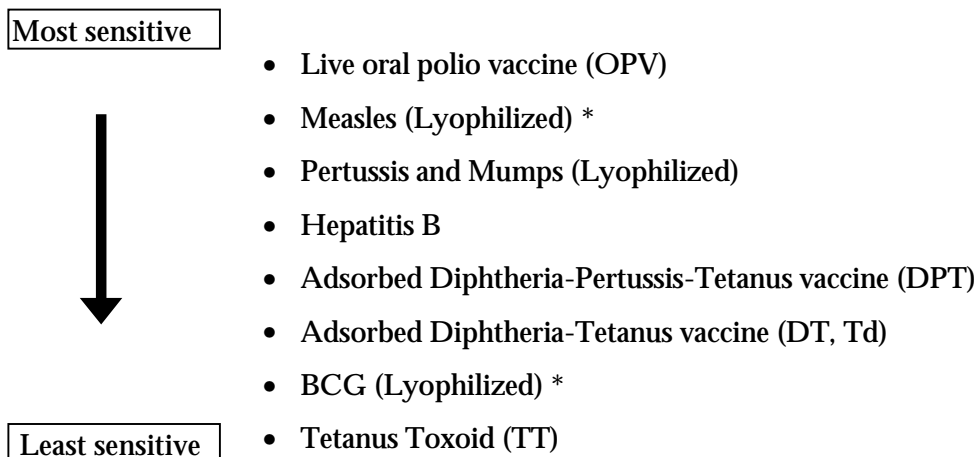

**\* Note: These vaccines become much more heat sensitive after they have been reconstituted with diluent.**

Some vaccines are also highly sensitive to being cold. Such vaccines will lose their potency entirely if frozen, although others can sustain freezing without any damage whatsoever. (Refer to Table 1) It is therefore vitally important to know the CORRECT storage conditions for each vaccine, and to ensure that each is kept always at the recommended conditions.



**Table 1: Sensitivity of vaccines to freezing**

Vaccines damaged by freezing	Vaccines unaffected by freezing
DPT DT Td TT Hepatitis B	BCG * OPV Measles * Mumps

**Note: Vaccines freeze at temperatures just below zero.**

- **BCG and measles vaccines must not be frozen after reconstitution**
- **diluent for any vaccine must never be frozen.**

In addition to being temperature-sensitive, several vaccines are also highly sensitive to strong light, and thus need to be kept in the dark as far as possible. BCG and Measles are those most affected. These vaccines must never be exposed to sunlight, and are given some protection by being supplied in vials of dark brown glass to reduce the penetration of light. This alone will not prevent light damage however, and great care must be taken to protect them during use. As with loss of potency due to heat, any loss of potency due to light is also permanent and irreversible.

Note that all losses of potency are CUMULATIVE, that is, each time a vaccine is exposed to incorrect temperature or strong light its potency will decrease. Since the vaccine may have already been exposed previously, any new exposure, however small, will increase the damage to the vaccine. Ultimately, due to cumulative damage, the vaccine may be completely destroyed, with all its potency lost.

Note also that even when stored at the correct temperature vaccines do not retain potency forever. Therefore the **expiry date** marked on a vial or packet of vaccine must be strictly observed even when correct storage temperatures have always been maintained.

## **1.5 Correct administration of vaccines**

### **1.5.1 Oral polio vaccine (OPV)**

The vaccine most commonly used is made from a LIVE ATTENUATED POLIO VIRUS, which is administered orally as a liquid. The vaccine is quickly destroyed by temperatures above +8°C and of the commonly used childhood vaccines, OPV is the most sensitive to heat. It is not damaged by freezing however, and can be safely frozen, thawed and re-frozen any number of times without damage. **The vaccine should not be refrozen or used, however, if the Vaccine Vial Monitor indicates that the vaccine is at the discard point (refer to Section 5.5).**

Administration: Vaccine is given orally (NEVER give by injection)

Doses needed: 4 doses to complete primary immunization (before 1 year)

Storage conditions: -15 to -25°C (central, oblast and rayon levels)  
0 to +8°C (health facility levels)

The WHO manual “Immunization in Practice” gives detailed instructions on the correct procedures for administering each vaccine.

---

### 1.5.2 *Measles vaccine*

Measles vaccine is made from a LIVE ATTENUATED MEASLES VIRUS. It is a freeze dried powder, which must be reconstituted before use. Reconstitution is **only** with diluent from the manufacturer of the vaccine in use. Administration is by subcutaneous injection. The dry frozen vaccine remains potent for a long period if stored under frozen conditions. Like OPV, it can be safely frozen, thawed and re-frozen any number of times without damage. The diluent however, must never be frozen. After re-constitution, the vaccine becomes very heat-sensitive, with rapid loss of potency so it must be used within **6 hours**. This is also very important because this vaccine does not contain a preservative to prevent contamination.

Administration: Vaccine is given by subcutaneous injection

Doses needed: 1 dose to complete primary immunization (before 1 year, or older if national immunization schedule specifies)

Storage conditions: -15 to -25° C (central, oblast and rayon levels)  
0 to +8° C (health facility levels)

### 1.5.3 *DPT vaccine*

DPT, sometimes called a “triple” vaccine, contains 3 components, DIPHTHERIA TOXOID, inactivated PERTUSSIS VACCINE and TETANUS TOXOID. It is a liquid vaccine, which is administered by deep intramuscular injection. The vaccine is heat-sensitive, although to a lesser extent than OPV and measles, but is immediately destroyed by freezing. The freezing temperature is approximately -3° C, so storage temperatures should never be less than 0° C to allow a margin for safety. When DPT is at rest the liquid is clear, with a white sediment forming at the bottom of the vial. Shaking of the vial makes the vaccine a white, uniformly turbid liquid, with no granules.

Administration: Vaccine is given by deep intramuscular injection in the thigh; do NOT give DPT in the buttock

Doses needed: 4 doses to complete primary immunization;  
3 doses before one year and the 4th dose at 16 - 18 months

Storage conditions: 0 to +8° C (at all levels of the cold chain)

Sometimes, small numbers of infants experience serious adverse reactions to DPT vaccine, usually due to the Pertussis component. Such infants should receive DT vaccine (i.e., Diphtheria with Tetanus vaccines only, without the “P” component) as an alternative for completing their primary series. **Minor** reactions to DPT vaccine, with local redness and mild fever, are frequent, and can occur in up to 50% of immunizations, but this subsides without treatment in one or two days. **NEVER** use adult formulation Td vaccine (i.e., Tetanus vaccine with reduced Diphtheria content) as a substitute for DPT vaccine.

### 1.5.4 *BCG vaccine*

BCG is a LIVE BACTERIAL VACCINE. It is a freeze-dried powder which must be re-constituted before use. Reconstitution is **only** with diluent from the manufacturer of the vaccine in use. Administration is by intradermal injection. The dry frozen vaccine retains potency for a long time if stored under frozen conditions, but is readily destroyed by sunlight and is thus supplied in dark brown glass ampoules to reduce light penetration. The vaccine is not damaged by freezing and can be frozen, thawed and re-frozen without damage. The diluent however, must never be frozen. In practice however, BCG vaccine is not normally stored in the frozen state. After reconstitution,

the vaccine rapidly loses potency and must be used within 6 hours. This is very important because the vaccine does not contain a preservative to prevent contamination.

Administration: Vaccine is given by intradermal injection

Doses needed: 1 dose to complete primary immunization (before 1 year)

Storage conditions: 0 to +8° C (at all levels of the cold chain)

### **1.5.5 Mumps vaccine**

Mumps vaccine is a freeze-dried powder, which must be re-constituted with diluent before use. Reconstitution must be **only** with diluent from the manufacturer of the vaccine in use. Administration is by deep intramuscular injection. The dry frozen vaccine retains potency for a long time if stored under frozen conditions and can be frozen, thawed and re-frozen without damage. The diluent however, must never be frozen. After reconstitution, the vaccine rapidly loses potency and must be used within 6 hours.

Administration: Vaccine is given by deep intramuscular injection in the thigh;  
do NOT give Mumps vaccine in the buttock

Doses needed: 1 dose given between 12 and 18 months

Storage conditions: -15 to -25 C (central, oblast and rayon levels)  
0 to +8 C (health facility level)

#### **IMPORTANT!**

- Measles, BCG and mumps vaccines must be reconstituted only with the diluent provided by the manufacturer of the vaccine in use.
- Never use other diluent.
- Diluent must be cold, between 0 and 8 degrees Celsius, before being mixed with the vaccine.
- When reconstituted, the vaccine must be used within 6 hours, and any remainder discarded.

### **1.5.6 Hepatitis B vaccine**

Hepatitis B Vaccine is a liquid vaccine available as a recombinant yeast or as a plasma derived preparation. It is administered in a deep intramuscular injection. The vaccine is about as sensitive to heat as DPT vaccine, and is destroyed immediately if frozen. The storage temperature should therefore never be below 0°C.

Administration: Vaccine is given by deep intramuscular injection in the thigh;  
do NOT give hepatitis B vaccine in the buttock

Doses needed: 3 doses to complete primary immunization (before 1 year)

Storage conditions: 0 to +8 C (at all levels of the cold chain)

**Table 2: Dosage and administration of EPI vaccines (summary)**

Vaccine	No. of doses for Primary Series	Administration	Dose
OPV	4	Oral	2 drops
Measles	1	Subcutaneous	0.5 ml
DPT	4	Deep intramuscular	0.5 ml
BCG <1yr	1	Intradermal	0.05 ml
BCG >1yr	1	Intradermal	0.1ml
hepatitis B	3	Deep intramuscular	0.5 ml
Mumps	1	Deep intramuscular	0.5 ml

The EPI vaccines may be obtained from a number of manufacturers, and in different vial sizes (number of doses/vial). The most common presentations and the recommended dose size in drops or cc/ml are shown in more detail in **Annex 1**.

**IMPORTANT:**

- All vaccines lose potency gradually, even at correct.
- Storage temperatures - observe expiry dates.
- All vaccines suffer much faster loss of potency when exposed to temperatures above +8 degrees C.
- Any loss of vaccine potency is irreversible.
- Damage due to successive exposures to heat or light is cumulative.
- Hepatitis B, DPT, DT, Td and TT are destroyed by freezing.
- BCG and measles vaccines are damaged by exposure to strong light as well as heat.

## **1.6 Policy on use of opened vials of vaccine**

Global policy on this matter used to be that opened vials of all vaccines were discarded at the end of each working day. In 1995, WHO recommended a changed global policy on the use of opened vials of vaccine as follows:

- (1) Opened vials of OPV, DPT, DT, TT and hepatitis B vaccines may be used in subsequent immunization sessions until a new shipment of vaccine arrives, provided that each of the following 3 conditions are met:
  - the expiry date has not passed;
  - the vaccines are stored under appropriate conditions (0 to +8° C), and
  - opened vials of vaccine which have been taken out of the health facility for immunization activities (e.g. outreach, NIDs) are discarded at the end of the day.
- (2) Opened vials of measles, yellow fever and BCG vaccines must be discarded within six hours.

---

(3) An opened vial must be discarded immediately if any of the following conditions apply:

- if sterile procedures have not been fully observed, or
- if there is even a suspicion that the opened vial has been contaminated, or
- if there is visible evidence of contamination, such as a change in appearance, floating particles, etc.

Decisions on whether and when to adopt this policy are the responsibility of the health ministry in each country. If your ministry has already adopted the “opened vial policy,” this will have implications for the logistics of your immunization programme, as discussed in later sections of this manual. If your ministry has NOT yet adopted the policy, you must continue to discard all opened vials after six hours, until a new instruction is issued.

## 2. The cold chain system

The cold chain system is a means for storing and transporting vaccines in a potent state from the manufacturer to the person being immunized. This is a very important component of an immunization programme, since all vaccines lose potency over time, especially if exposed to heat, and in addition, some also lose their potency when frozen. It is obviously pointless to immunize with impotent vaccine, and efforts to reach extremely high levels of immunization coverage will be useless if the vaccine being administered has insufficient potency to give the necessary protection. Attention to maintaining correct temperatures during storage and transport of vaccine is thus a major task for health workers.

The cold chain system comprises three major elements:

- **Personnel**, who use and maintain the equipment and provide the health service;
- **Equipment** for safe storage and transportation of vaccines; and
- **Procedures** to manage the programme and control distribution and use of the vaccines.

Competent personnel and efficient procedures are a vitally important part of the cold chain system:

**Figure 1** illustrates a typical cold chain system, showing the various steps which may be involved in delivering vaccine from the manufacturer to the person being immunized. Not all countries have an identical system, but the vaccine must always be maintained at a safe temperature throughout its entire journey; - during transport, while waiting at the airport, when being kept in cold store, freezer or refrigerator, and finally, during the course of an immunization session at the health facility.

**Figure 1: A typical cold chain system**

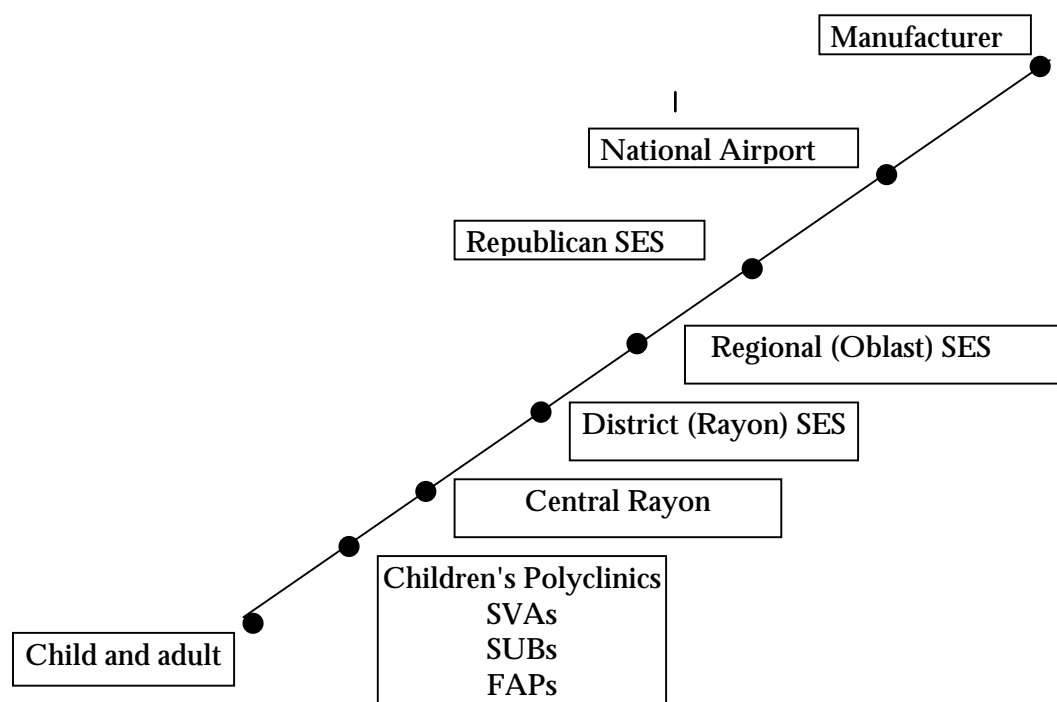

**REMEMBER:**

- Even the most expensive and sophisticated equipment will not ensure an effective cold chain if not correctly used and managed by health personnel.

## 2.1 Vaccine storage

Table 3 shows the maximum times and temperatures for storage of EPI vaccines at different levels of the cold chain as recommended by WHO. During transport between one level and the next, all vaccines must be maintained at a temperature between 0° and +8°C. If unopened and OPV, Measles or Mumps vaccines become unfrozen during transit, they can be safely re-frozen at the next level without any harm or loss of potency to the vaccine.

**Table 3: Recommended vaccine storage temperatures/times for different levels of the cold chain**

Vaccine	Republican SES (National)	Regional SES (Oblast)	District SES (Rayon)	Health Facilities
Maximum Storage time	up to 6 months	up to 3months	up to 1 month	up to 1 month
OPV	-15 to -25°C	-15 to -25°C	-15 to -25°C*	0 to +8°C
Measles	-15 to -25°C	-15 to -25°C	-15 to -25°C*	0 to +8°C
Mumps	-15 to -25°C	-15 to -25°C	-15 to -25°C*	0 to +8°C
DPT	0 to +8°C	0 to +8°C	0 to +8°C	0 to +8°C
Hep B	0 to +8°C	0 to +8°C	0 to +8°C	0 to +8°C
DT	0 to +8°C	0 to +8°C	0 to +8°C	0 to +8°C
Td	0 to +8°C	0 to +8°C	0 to +8°C	0 to +8°C
TT	0 to +8°C	0 to +8°C	0 to +8°C	0 to +8°C
BCG	0 to +8°C	0 to +8°C	0 to +8°C	0 to +8°C

**Notes:**

- (1) If freezers are not available at rayon level these vaccines may be stored at 0° to + 8°C.
- (2) This table shows maximum storage times at each level. Maximum times are based on the relative security of storage expected at each level, and together ensure that any vaccine will take at most one year to be sent through the cold chain and be used. Normally you would expect to use most vaccine stocks before the maximum time is reached.
- (3) Remember to check the expiry dates of all vaccines and ensure that they will not expire during storage or before they can be distributed and used.
- (4) Rotate vaccine stock: vaccine received first should be distributed or used first (“First In, First Out”) unless a Vaccine Vial Monitor (VVM) shows that another batch should be distributed or used first (see Section 5.5).

## **IMPORTANT!**

- Vaccine must always be transported in insulated boxes with sufficient ice to ensure it remains between 0 and +8 °C. Never use un-insulated boxes, or forget the ice!

### **To summarise, if you work:**

- **At the national level** (e.g., at the Republican SES),  
keep your vaccines for a maximum of **6 months** :
  - store OPV, Measles, and Mumps vaccines at -15 to -25° C;
  - store Hepatitis B, DPT, DT, Td, TT and BCG at 0 to +8° C;
  - send vaccines to regions in insulated containers at 0 to +8° C.
- **At the regional level** (e.g., at the Oblast SES),  
keep your vaccines for a maximum of **3 months** :
  - store OPV, Measles, and Mumps vaccines at -15 to -25 o C;
  - store Hepatitis B, DPT, DT, Td, TT and BCG at 0 to +8o C;
  - send vaccines to districts in insulated containers at 0 to +8° C.
- **At the district level** (e.g., at the Rayon SES),  
keep your vaccines for a maximum of **1 month** :
  - store OPV, Measles, and Mumps vaccines at -15 to -25 o C, if possible;
  - store Hepatitis B, DPT, DT, Td, TT and BCG at 0 to +8 o C;
  - send vaccines to health facilities in insulated containers at 0 to +8° C.
- **At the health facility level** (e.g., at the Children's Polyclinic, SVA, SUB or FAP):
  - keep all your vaccines for a maximum of 1 month:
  - store all vaccines at 0 to +8° C.

## **REMEMBER!**

- Storage times shown are maximum periods at each level.
- If your cold chain equipment is not reliable, storage times should be shorter than these, amounts stored should be kept small, and deliveries should be more frequent to minimize the risks of damage and loss.
- Even if storage temperatures are always correct, check the expiry dates.



---

## 2.2 Vaccine potency

If a vaccine loses some or all of its potency due to exposure to heat, its outward appearance may be unchanged. Previously, a laboratory test was needed to determine whether it could still be used. The Cold Chain Monitor Card (section 5.4) was the first device to give a visual indication of possible loss of potency in a carton of vaccine because of exposure to temperature. In 1996, a new kind of monitoring device became available which gives a visual indication of vaccine potency for individual vials of foreign manufactured OPV. The Vaccine Vial Monitor (VVM) is a small indicator attached to each vial, which keeps a constant record of its exposure to heat. If the vaccine is exposed to temperatures above +8°C, the indicator progressively changes colour, and gives health staff an immediate warning that the vaccine has been damaged. In 1997, this type of indicator was only used on OPV vials, but similar indicators are being developed for other vaccines also. (see section 5.5)

## 2.3 Vaccine stock quantities

It is important for the correct quantity of vaccine stock to be kept at each level of the cold chain. If you keep too little vaccine, health facilities may run out of stock and the immunization programme may be interrupted. On the other hand, if you keep too much vaccine, there may be insufficient storage space in your cold chain, some vaccine may be stored longer than recommended and risk expiry before it can be used, and there may not be enough vaccine to supply to other parts of the country.

### How much vaccine is needed at each level of the cold chain?

To estimate the quantity of vaccine needed for primary immunization in any area (i.e., for a health facility, a rayon, an oblast, or for the whole country), the following information will be needed:

- the number of children in the area to be immunized during the next 12 months;
- the number of doses needed per child for each vaccine;
- the estimated index of vaccine use (also called wastage factor) for each vaccine;
- the number of vaccine deliveries planned during the next 12 months;
- the amount of reserve vaccine stock (in %) to be kept in the main store of the area;
- the balance of vaccine stock remaining in the main store at the date of the estimate.

The following points should be kept in mind when estimating vaccine needs. They will help you to avoid some mistakes which commonly occur during the preparation of estimates.

#### (1) Number of children to be immunized:

For primary immunization, this is the total number of children expected to be born in the next 12 months in the area for which you are estimating. (i.e., in the territory of the health facility, the rayon, the oblast, or in the whole country). This will be a projection, and you may take the number of newborns from the previous year as a basis for the estimate.

Remember that you must not subtract the number of children who might have temporary or permanent contraindications to immunization. All children must be included in the annual plan for primary immunization, and any children from the previous year who did not yet receive their primary immunization (backlog) should also be added on to this year's total.

---

**(2) Number of doses needed per child:**

This will be in accordance with your national immunization schedule, and for the **primary series** (during the first 2 years of life) may include:

OPV	-	4 doses
Measles	-	1 dose
DPT	-	4 doses
BCG	-	1 dose
Hep B	-	3 doses (if part of the national schedule)
Mumps	-	1 dose (if part of the national schedule)

For **revaccinations**, calculate dose requirements separately, according to the national immunization programme schedule.

Similarly, for mass immunization, outbreak control or special campaigns keep calculations separate from estimates of primary immunization needs. Remember that bigger vial size may sometimes be preferable for mass campaigns.

**(3) Index of vaccine use (or wastage factor):**

The actual wastage factor for each vaccine can be calculated from your records of numbers of immunizations given and amounts of vaccine used during a certain period, i.e., one month, 3 or 6 months, or over a full year.

In general, more accurate figures are obtained if long, rather than short periods of time are used as the basis of calculation. The wastage factor is calculated separately for each vaccine, and for any period for which you have reliable records, using the formula:

$$\text{Index of vaccine use (or wastage factor)} = \frac{\text{Doses of vaccine used in a certain period}}{\text{Immunizations given during the same period}}$$

The index will most likely be different for each vaccine, and for each vaccine it may vary over different periods of time, i.e., from one year to the next. It will also vary for the same vaccine according to the type of activity (for example routine sessions versus mass campaigns). It is useful to calculate an average figure for each vaccine, which can be found from your records over the last 5 years, for example. This figure can then be updated each year by adding the new data on numbers of immunizations given, and amounts of vaccine used during the last 12 month period.

Always use your data to calculate **actual** wastage rates for your particular situation, rather than using assumed values. If you have insufficient data for making the calculation, your information system is inadequate. Take steps as soon as possible to improve recording and reporting so that the necessary data can be collected and used for future calculations.

**(4) Number of deliveries planned in the next 12 months:**

Your programme should have a fixed schedule for deliveries of vaccine between each level of the cold chain and the next. Usually, there will be longer delivery intervals at the central levels, and shorter intervals at the periphery, but they should not exceed the maximum storage periods for each level described in “Vaccine Storage”, Section 2.1 above. The choice of delivery interval is always a compromise, fewer deliveries mean lower shipping charges, but more vaccine will have to be sent in each delivery, and a larger and more expensive cold chain will be needed.

Many programmes find that 4 deliveries per year at the national level, 4 deliveries per year at the regional (oblast) level, and 12 deliveries per year at the district (rayon) and health facility (SVA,

---

SUB and FAP) levels give the best balance. Using figures appropriate for your own programme, calculate amounts of vaccine to be sent in each delivery by dividing annual needs by the number of deliveries planned during the year.

As noted in **Section 2.1**, if your cold chain equipment is not reliable, maximum storage times should be shorter, amounts stored should be kept small, and vaccine deliveries should be more frequent to minimize the risks of damage and loss of stock in the event of cold chain failures. Obviously, in all areas where you know the cold chain to be unreliable, steps should be taken to improve the situation as quickly as available resources permit.

**(5) Reserve vaccine stock to be kept in hand (in doses):**

Vaccine storage points at all levels of the cold chain should always keep a reserve stock balance in hand. This is to allow for unexpected increases in vaccine use, resulting from an outbreak of disease, for example, or late arrival of a planned vaccine delivery. The amount of reserve needed at any level may depend on its remoteness from the central store, the reliability of vaccine deliveries, or the capacity of equipment available.

Typically, the amount of reserve stock kept is 20-25% of the amount used during one delivery period. However, any amount which ensures you never completely run out of stock may be chosen, according to local experience.

When you have decided what reserve stock level is needed for each storage point, this amount is called the minimum stock for the store. Stocks should never be allowed to fall below this absolute minimum.

The maximum stock to be kept at any storage point should be the total vaccine need as calculated above, plus the amount decided as the reserve stock.

Provided your immunization programme is running normally, the amount of stock at each storage point should always remain between these two levels, never more than the maximum and never less than the minimum. This would indicate a well-run store, with good stock control.

**(6) Balance of vaccine stock remaining in the store (in doses):**

All the above calculations allow you to determine vaccine needs, but this is normally not the amount to be ordered or purchased. You must now check the balance of vaccine stock remaining in the store, and subtract this from total calculated needs. Forgetting this last, but very important step often results in large overstocks accumulating, serious overcrowding of cold chain equipment and expiry of vaccines before they can be used

**(7) What vial sizes to order:**

The most useful size of vial to order (1,2,5, 10 or 20 dose, etc.) will depend on the type of immunization being conducted (routine or mass campaign), the numbers of people to be served and the numbers of health facilities to which vaccine must be sent. For example, 1000 doses in 20 dose vials gives 50 vials for distribution, but in 10 dose vials gives 100 vials for distribution. However, remember that smaller vial sizes are normally more expensive, so a compromise must be reached.

### **IMPORTANT!**

- Always subtract the stock balance remaining in the store from calculated total needs before placing your vaccine order.
- Always specify vial size required when ordering.

### **And remember!**

- All calculations and estimates must be in doses of vaccine. Do not confuse doses with numbers of vials and ampoules.

## **2.4 Vaccine stock records**

All vaccine storage points must keep a complete and updated stock record book. Minimum information to be recorded for each vaccine should include:

- Name of vaccine, batch number & expiry date, *vial size*;
- Quantity received and sources of supply, (in doses);
- Quantity issued and to whom sent, (in doses)
- For BCG, measles, and mumps: quantities of diluent received and issued;
- Balance in stock after each transaction, (in doses);
- Date of each transaction;
- Physical stock check at the end of each page. (in doses).

The record should be kept by the storekeeper or person responsible for looking after the vaccines, and must be updated every time vaccine enters or is issued from the store. A record, which is not kept up to date, gives false information, and is of no value to the manager. It can also lead to over or under-stocking of your store and cause confusion and disruption to your programme.

The stock record must also be checked regularly for accuracy. This can be done by making a physical count of the actual quantities of vaccine in stock, and comparing this to the amount shown in the stock record book. Any difference must be immediately corrected by updating the record to show the correct figures. The check for accuracy should be done at the end of each page in the record book, or at the end of each month, if this is reached before the end of one page.

A sample stock record sheet, showing how the minimum necessary information could be collected, is included at **Annex 2**.

### **ESSENTIAL ACTIONS!**

- Update the stock record every time vaccine is put in, or taken out from the store;
- Record the quantity of diluent provided with freeze-dried vaccines. Never issue freeze-dried vaccines without the correct diluent;
- Always complete the “stock balance” figure, so that you have a constant record of stock available;
- Conduct physical check for accuracy at the end of each page in the record book, or at the end of each month (if this is reached before the end of one page).

---

## 2.5 Vaccine arrival report

If you work at the national level (e.g., at the Republican SES) you must keep a record of the details and arrival conditions of ALL vaccine deliveries received at your store. This is done using a special document known as a Vaccine Arrival Report, which is required in addition to the normal receipt issued whenever supplies are delivered. A Vaccine Arrival Report is required for EVERY vaccine shipment, whether it comes from a foreign manufacturer, or from within the NIS, (e.g., from the Russian Federation). The document provides vital information for your own Ministry, but will also be essential if this vaccine was provided through a programme of technical assistance or other donor support to your programme. An example of a Vaccine Arrival Report is included at **Annex 3**.

---

## 3. Cold chain equipment and its use

As shown in **Section 2.1**, there are different vaccine storage conditions appropriate to each level of the cold chain. Thus, each level requires different storage equipment depending on the quantity of vaccine to be stored, the duration of storage and the temperature necessary. All equipment must be able to keep vaccines safely whatever the outside temperature, and however the climate varies at different times of the year.

There are also different types of equipment designed for transporting vaccines between the various levels of the cold chain, and for use during immunization sessions.

All types of cold chain equipment contain one or more of a series of organic gas compounds, used either as their working fluid, in manufacture of their insulation, or both. These gas compounds, known as CFC gases, were once considered to be ideal for cold chain purposes, but have more recently been found to have harmful effects if allowed to escape into the environment. Thus, a new range of cold chain equipment was introduced from 1996 to replace those using CFC gases. The new equipment is described as being CFC-free equipment. The symbol shown in **Figure 2** is used on refrigerators, cold boxes and vaccine carriers to indicate that the equipment has been made using CFC-free material for the insulation and CFC-free gas for the refrigerator's cooling system. These materials are less harmful to the environment than those previously used for the manufacture of such equipment.

**Figure 2: WHO/EPI symbol for CFC-free cold chain equipment**

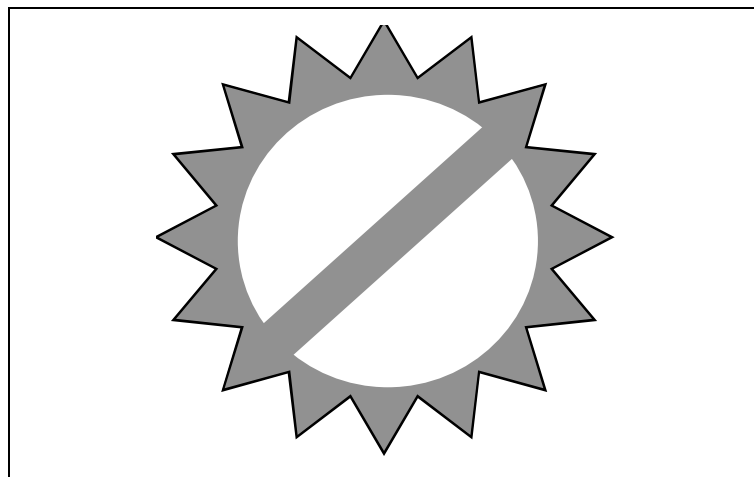

CFC-free refrigerators and cold boxes, however, perform differently compared with the same equipment made with CFC insulation, regarding the length of time they will keep vaccines safe. If you receive CFC-free equipment with the above symbol, therefore, ask the supplier for the appropriate performance information, because it will differ from that of equipment of the same kind, which you may already be using.

Obviously, all CFC-free equipment must still pass WHO tests before it can be accepted for use in national immunization programmes.

In order to maintain a continuous cold chain during the entire journey from the vaccine manufacturer to the child being immunized, it is most important that the equipment used for storage, packaging and transport of vaccine is properly used. The following points will help you to use your equipment correctly.

### 3.1 Equipment for vaccine transportation

All transportation links in the cold chain must be able to protect vaccines from heat and sunlight. However, in some winter conditions, when atmospheric temperatures are below 0° C, you may also have to take measures to prevent vaccines from becoming too cold. Cold boxes and vaccine carriers are designed to give the required protection.

The “cold life” of a cold box or vaccine carrier is the number of hours it will keep the vaccines at a safe temperature. According to WHO test procedures, it is the number of hours the cold box or vaccine carrier will maintain a temperature below +10°C after it has been loaded with the recommended number of frozen icepacks. The cold life of each cold box or vaccine carrier differs and depends on the following factors:

- Type of cold box or vaccine carrier, insulation material, thickness, method of construction and foaming agent used;
- mass and initial temperature of icepacks that are put into the cold box or vaccine carrier;
- the number and duration of openings; and
- the surrounding air temperature. This factor greatly affects the cold life, the lower the air temperature, the longer the cold life as shown in Table 4.

Table 4: Cold life of different cold boxes

Type of cold box	Cold life at 32°C	Cold life at 43°C
Electrolux RCW 25	226 h	181 h
“IGLOO” 20 litre	not tested	84 h
“IGLOO” 4.4 litre	not tested	50 h
“THERMOS” 1.7 litre	40 h	33 h
“Russian”	not tested	not tested

Figures in Table 4 are from WHO tests on CFC equipment supplied to countries before 1996. They are based on equipment loaded with the recommended number of frozen icepacks and kept unopened during the tests. (“Russian” boxes have not been tested by WHO, however.) The same types of cold boxes made from CFC-free materials may have a shorter cold life, but must still pass WHO tests.

In the winter season air temperatures get extremely low in certain areas, and transport of DPT, DT, Td, TT and Hepatitis B must be done with utmost care to avoid freezing the vaccines. In this case, the cold box must protect vaccines from becoming too cold, and the “warm life” is the number of hours it will keep the vaccines above their freezing point. To protect these vaccines from freezing under winter conditions, the following measures will help:

- Fill the icepacks with water from the tap, **but do not freeze them**;
- Keep DPT, DT, Td, TT and Hepatitis B in the center of the cold box or vaccine carrier, and farthest from the icepacks;
- Use a Freeze Watch Indicator in addition to the normal CCM and thermometer (refer to section 5);
- Do not leave the cold box or vaccine carrier outdoors or in very cold rooms for longer than necessary;
- Do not leave cold box or vaccine carrier in unheated means of transport longer than necessary.

### **3.1.1 Cold boxes**

A cold box is an insulated container with a tight fitting insulated lid. The temperature inside the box is maintained by icepacks. The cold box is designed for:

- Collection and transport of large quantities of vaccine at temperatures between 0° to +8° C;
- Storage of vaccine during maintenance periods, e.g. when cleaning or defrosting a refrigerator or freezer; and
- Emergency storage of vaccine, e.g., during breakdowns of cold chain equipment, power failures, and similar situations.

Different levels of the cold chain require different types and sizes of cold boxes, according to the population served. An example is shown in Figure 3:

**Figure 3: Cold box used in the cold chain**

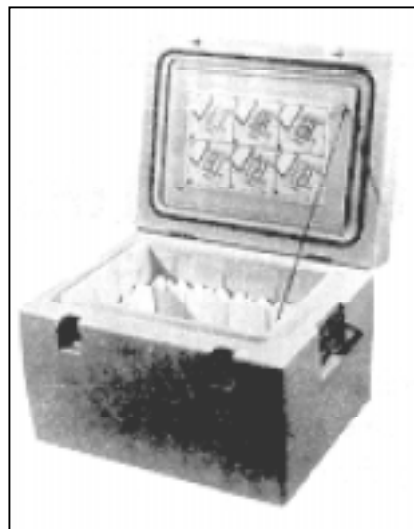

### **3.1.2 International vaccine packaging containers**

Internationally procured vaccines are transported in vaccine packaging containers, sometimes called “one-way” containers. These containers are made of polystyrene foam and are quite sturdy, give good protection from heat and cold, and conform to WHO/UNICEF guidelines for international vaccine shipping.



---

Containers may be used as a cold box at Regional and District level as long as they are in good condition, i.e. they are not broken, partly torn or damaged in any other way. The ones in which international shipments of polio or measles vaccine have been received are best for this, although their performance will not normally be as good as a real cold box.

When used, these containers should be loaded with vaccine and icepacks in the same way as a regular cold box. (see below).

**NOTE:**

The cold life of one-way shipping containers is not as good as those of real cold boxes.

Limit their use to the less heat sensitive vaccines - DPT, DT, Td, hepatitis B, as far as possible.

**How to load a cold box**

Remember that DPT, DT, Td, TT and hepatitis B vaccines must not be frozen (refer to **Table 1**). If vials of these vaccines make direct contact with frozen icepacks in a cold box, they may easily freeze and the vaccine will be destroyed. To avoid such damage:

- icepacks should not be taken from a freezer and placed directly in a cold box containing these vaccines; leave icepacks for a few minutes until water droplets appear on their surface before putting them in the cold box;
- place a layer of plastic foam, cardboard or similar packaging material between the vaccine packets or vials and the icepacks. This will act as an insulating barrier, and protect vaccines from freezing.

For other vaccines, i.e., OPV, Measles and Mumps, *these* precautions are not necessary, and icepacks may be placed in a cold box direct from the freezer. Prepare a cold box as follows:

- Take the required number of icepacks from a freezer;
- if required, wait for a few minutes until water droplets appear on the surface;
- wipe the icepacks dry and place them so as to cover bottom and internal walls of the cold box;
- if required, put plastic foam, cardboard or similar material to protect DPT, DT, Td, TT and hepatitis B vaccines;
- place vaccines, thermometer and/or Cold Chain Monitor card carefully in the box; (if mixed vaccines, put OPV, measles, BCG at the bottom and closest to the icepacks; DPT etc in the center and farthest from the icepacks)
- place cardboard or similar material and additional icepacks on top of vaccines;
- close the lid tightly;
- do not include diluent for freeze-dried vaccines in the cold box. This does not need to be kept cold during transport, and will occupy useful space in the cold box.

Figure 4: How to load a cold box

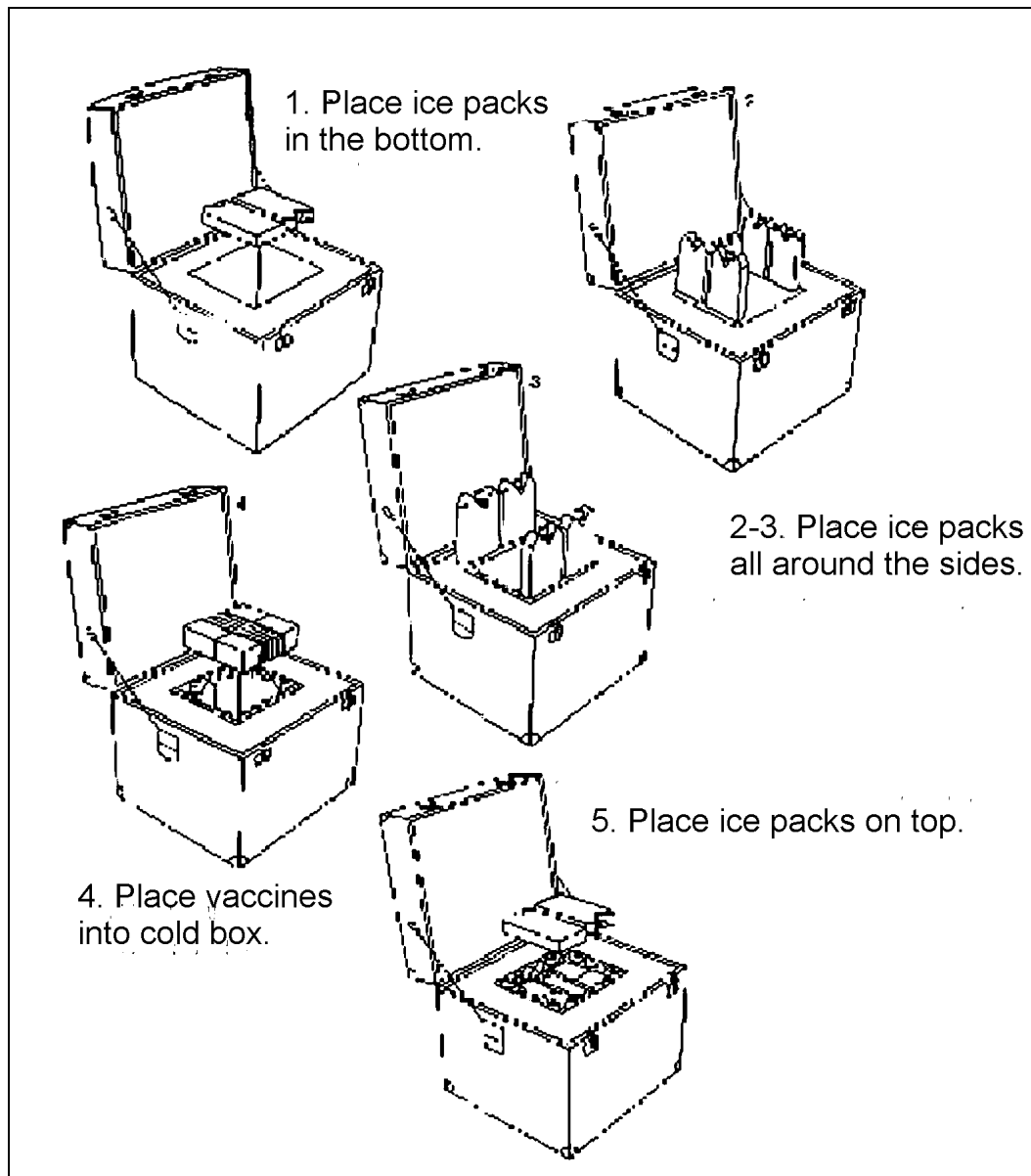

Don't use excessive ice, especially for short journeys with DPT or other adsorbed vaccines.

### 3.1.3 Vaccine carriers

A vaccine carrier is an insulated box with a tight fitting insulated lid. The temperature in the vaccine carrier is maintained by icepacks. The vaccine carrier is designed for:

- Transportation of small quantities of vaccine at a temperature between 0° and 8° C within one working day;
- Storage of small quantities of vaccine needed for immunization during the working day, thus avoiding frequent opening of the refrigerator;
- Storage of small quantities of vaccine in emergency situations, e.g., during breakdowns of cold chain equipment, power failures, and similar situations.

Some vaccine carriers now have a foam pad fitted under the lid (Figure 23); this has slits which safely hold opened vials in use, and protects the other, unopened vials inside the carrier. This avoids having to open and close the lid itself each time an opened vial is needed.



**Figure 5: Vaccine carriers**

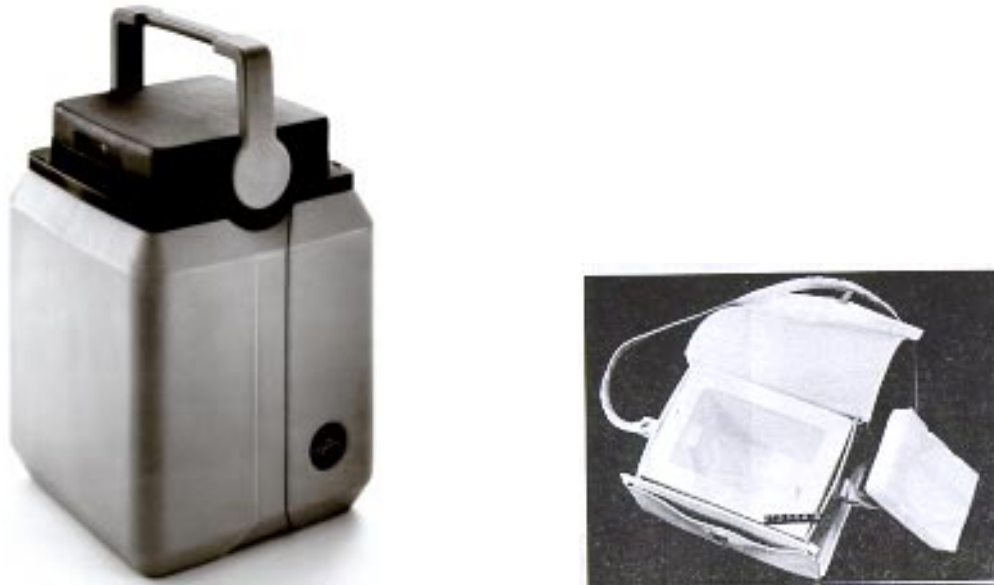

**How to load a vaccine carrier**

Follow the same instructions as given above for loading a cold box, **but in this case note that diluents for freeze-dried vaccine should be packed together with the vaccines.** Instructions are otherwise identical.

**Figure 6: How to load a vaccine carrier**

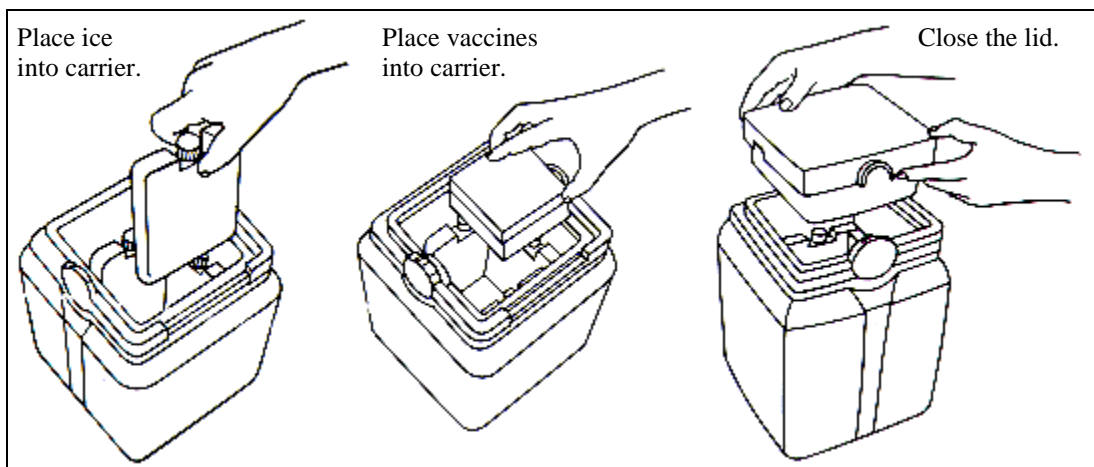

### 3.1.4 Icepacks

Icepacks are rectangular plastic containers to be filled with plain water. They come in many different sizes, although WHO recommends only two sizes:

- 0.4 liter to be used with vaccine carriers.
- 0.6 liter to be used with cold boxes.

The icepacks, once frozen, are used to maintain the temperature between 0 and +8°C in cold boxes and vaccine carriers.

**Always** have 2 sets of icepacks for each cold box or vaccine carrier - one set to be frozen while the other is being used.

**Figure 7: How to fill an icepack**

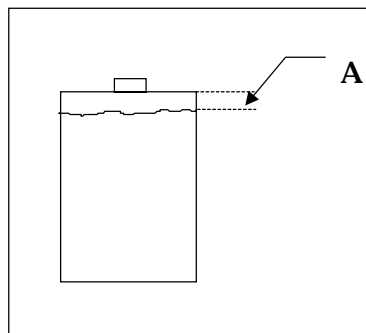

#### How to prepare icepacks for use

- Fill the icepack with water to level A, as seen in Figure 7, this will leave some room for the water to expand as it freezes. Most icepacks indicate the maximum admissible water level.
- Fit the sealing plug (if applicable) and screw on the lid tightly, making sure there are no leaks.
- Place the icepacks in a freezer or a freezing compartment of a vaccine refrigerator. For faster freezing, arrange the icepacks on one edge so that as many as possible have contact with the evaporator. See Figure 8.
- It normally requires 12 hours in a freezer and 24 hours in a freezing compartment of a refrigerator for an icepack to be completely frozen.

**Figure 8: Arranging icepacks for freezing**

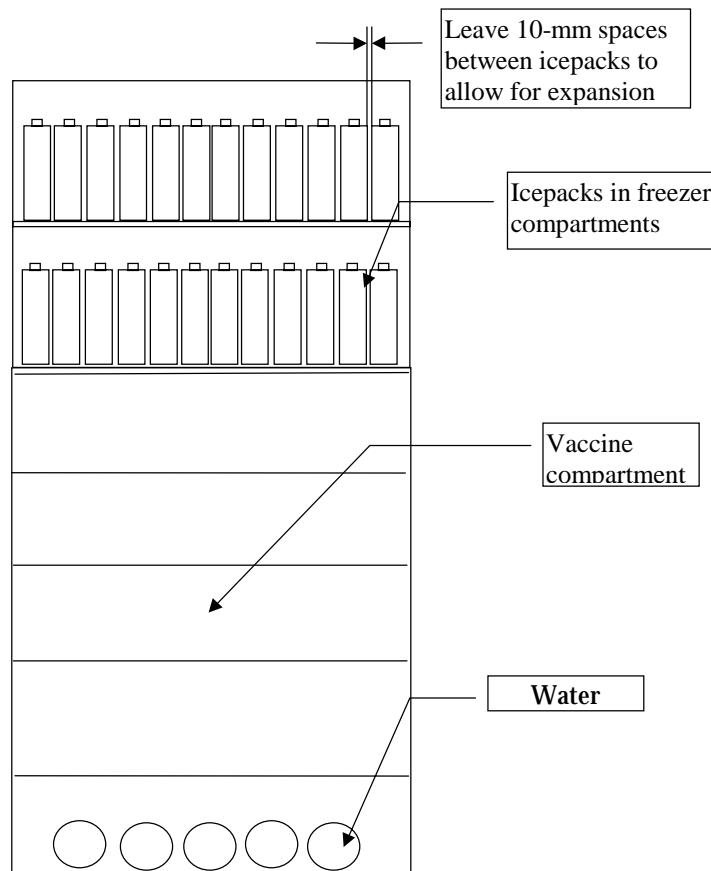

### 3.2 Equipment for vaccine storage

Cold Chain equipment designed for vaccine storage has to meet two major requirements:

- It must ensure optimum temperature conditions for vaccine storage all year round;
- It must be large enough to hold the maximum vaccine stock to be stored at the level of the cold chain where it will be used.

The different quantities of vaccine to be stored at each level in the cold chain *require* different equipment. Regular temperature monitoring is essential for all types.

**National level (i.e., at the Republican SES)**

At the national level the following equipment is normally used:

- Cold rooms, or large top-opening refrigerators;
- Freezer rooms or large top-opening freezers;
- Icepack freezers

In some republics, such equipment is also used at the oblast level.

### 3.2.1 Cold room

A cold room is a store where a refrigerating unit generates and maintains the temperature conditions between 0 to +8°C required to cool the vaccines. (see Figure 9)

**Figure 9: Cold room or freezing room**

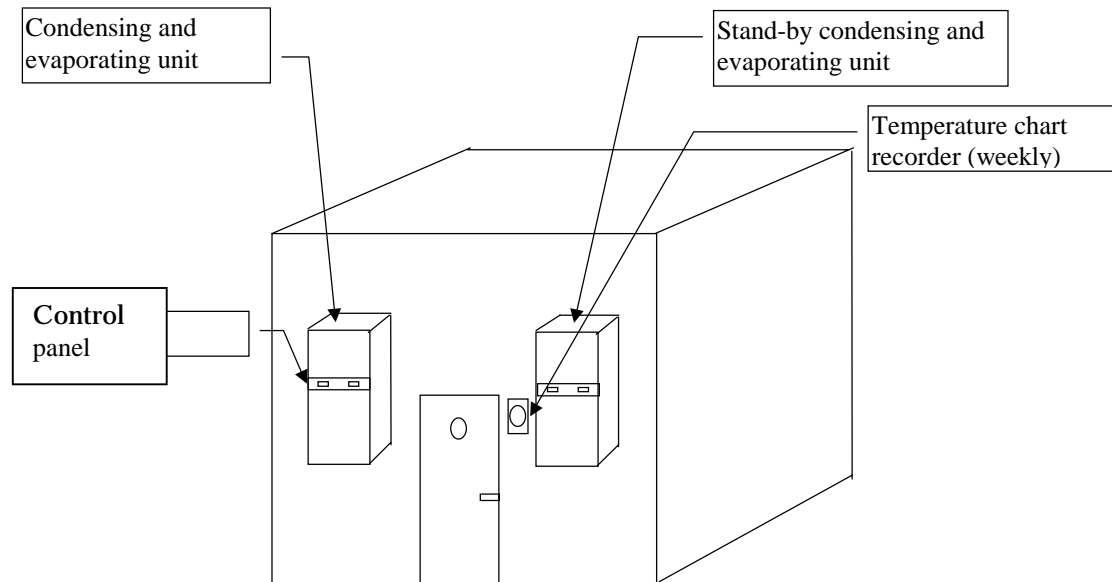

Cold rooms are used for:

- storage of very large quantities of vaccine between 0 to +8°C
- providing a secure facility for national or regional reserve stocks
- providing a national or subnational distribution point.

A cold room is a complex engineering structure, and trained workers, both for the vaccine storage and for the technical maintenance must operate it. Remember the following points for loading, unloading and maintenance of a cold room:

- Specific areas should be marked for each vaccine type;
- leave spaces between each row of vaccine boxes to allow free circulation of the cool air;
- do not place DPT, DT, Td, TT and hepatitis B vaccines in the direct airflow from the cooling machinery, where they may become frozen;
- unpacking, sorting and packaging of the vaccine into cold boxes must be done inside the cold room or in a cool place nearby;
- change paper charts for recording thermometers regularly (usually each week), and write on each chart the date for the recording period which it covers;
- if there is a standby generator, ensure that it always has an adequate fuel supply, and regularly check for correct operation. Run for approximately one hour at least once every week.

Large top-opening or ice-lined refrigerators are sometimes used at the national level instead of a cold room if quantities of vaccine to be stored are not very large.

### 3.2.2 Freezer room

A freezer room generates and maintains temperatures between  $-15$  and  $-25^{\circ}\text{C}$ . They are designed to keep very large quantities of polio, measles and mumps vaccines in a frozen state. The main operational points are the same as those for a cold room (refer to Section 3.2.1 above). However, remember to use gloves and a warm coat when working inside the freezer room.

#### **IMPORTANT!**

- Always wear suitable protective clothing when you are working inside a freezer room.

### 3.2.3 Top-opening freezer

A freezer generates and maintains a temperature between  $-15$  and  $-25^{\circ}\text{C}$ . Freezers are used for:

- storage of OPV, measles and mumps vaccines between  $-15$  and  $-25^{\circ}\text{C}$ ;
- storage of frozen icepacks and, if necessary, freezing of icepacks.

**Figure 10: Top-opening freezer**



Top-opening freezers are frequently used at national, regional or district vaccine stores where large quantities of frozen vaccine have to be kept. Remember the following points when using top-opening freezers:

- Keep the thermostat adjusted so that the temperature is always between  $-15$  and  $-25^{\circ}\text{C}$ .
- If vaccines and icepacks must be kept in the same freezer put in only small quantities of water filled packs at a time. Adding a large quantity of unfrozen icepacks at one time can raise the temperature to a level that endangers the vaccine.

### 3.2.4 Icepack freezer

This is a special, front-opening freezer for use at national and sometimes at regional (oblast) level to freeze large quantities of icepacks. It can hold up to 136 large icepacks (0.6 litre size) and freeze them faster than in an ordinary chest freezer. Performance depends on air temperature, but at least 60 large icepacks can be frozen in 24 hours.



**Remember the following points when using an icepack freezer:**

- Freeze as many icepacks as possible at one time and after freezing, store them in a chest freezer if available.
- Place the icepacks on edge so that the maximum number can be in direct contact with the shelves. Leave 1-cm space between each, because they expand when frozen (see **Figure 8**).

**Figure 11: Icepack freezer**

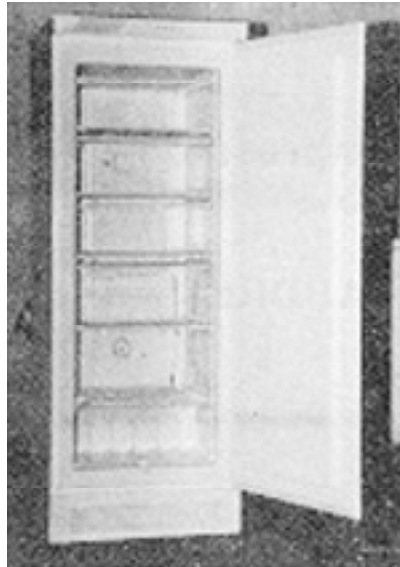

**SUMMARY POINTS!**

- At the national store, keep all vaccines for a maximum of 6 months.
- Store OPV, measles and mumps vaccine in freezer rooms or freezers at  $-15$  to  $-25^{\circ}\text{C}$ .
- Store DPT, DT, Td, BCG and hepatitis B vaccines in cold rooms or refrigerators at  $0$  to  $+8^{\circ}\text{C}$ .
- Do not freeze any diluents. Store the diluent in the refrigerator at  $0$  to  $+8^{\circ}\text{C}$ , and make sure that the quantity and type of diluent match the freeze dried vaccines in stock.
- Do not put *too* large quantities of unfrozen icepacks into a chest freezer which contains OPV, measles or mumps vaccines; use the icepack freezer to freeze them first, and then transfer them to the chest freezer for storage.

---

## Regional level (i.e., at the Oblast SES)

At the regional level the following equipment is normally used:

- Large top-opening refrigerators, “Ice-lined” refrigerators, cold rooms;
- Large top-opening freezers;
- Icepack freezers.

### 3.2.5 Voltage stabilizers; selection and use

Any item of cold chain equipment which operates on electric power is designed to be used with a specific electrical supply voltage, or in some cases, with a choice of several different supply voltages. If the supply voltage is incorrect or fluctuates from the correct value, the cold chain equipment can easily be damaged. This results in the need for costly replacement of motors, compressors, heater elements or other electrical components.

#### Problems with power supplies:

There are several ways in which the power supply may be incorrect:-

- the supply voltage may be constantly higher or lower than the design voltage, or;
- the supply may be intermittent, with frequent cuts and re-connections, or
- the voltage may fluctuate frequently from the correct value, with sudden ‘surges’ during which excessive voltage is supplied.

Each of these can cause immediate damage to cold chain equipment, but the damage can be prevented or reduced by installing a **voltage regulator** between the cold chain equipment and the electrical supply point. This corrects the supply voltage, removes the fluctuations, and so protects the equipment. A voltage regulator will add to the capital cost of the cold chain, but should prolong the life of equipment and in areas with poor power supply, is generally cost-effective.

#### Types of voltage regulator

There are several types of voltage regulator :

(1) **Pure Transformer regulators** are the most reliable type since they have no moving parts or electronic components, but they are usually the most expensive. This type uses a combination of magnetic flux and transformer principles to monitor the supply voltage, and if it is incorrect, to regulate it to the correct value as required by the equipment.

(2) **Solid State regulators** are also generally reliable and again have no moving parts, but use electronic components to monitor the supply voltage, and if necessary, to apply a correction. This type is less expensive than the pure transformer type, and is the most commonly used for small and medium-sized cold chain equipment. Such regulators are available for both inductive-load equipment, such as compression refrigerators or freezers, and for resistive-load equipment such as absorption refrigerators or steam sterilizers.

(3) **Electronic Servo regulators** contain electric motors and actuators together with variable-voltage transformers and electronics to monitor the supply voltage, and if necessary, regulate the output to the equipment. Because the output voltage is motor-regulated, this type is very accurate, and can control over a wide range of voltages. Costs are generally less than the types described above, but the moving parts mean that it is more complex and more sensitive, and unless treated with proper care, may cause problems.

---

## How do you know if a voltage regulator is needed ?

A voltage regulator should be considered as an essential item of capital equipment in any of the following situations:-

- in areas where room lights often change suddenly from bright to dim, or sometimes become very bright for short periods;
- in any area where the room lights are often dimmer than expected;
- in all areas where power supplies are irregular, or where cuts and interruptions are common;
- in all areas where other equipment which uses the electricity supply - such as light bulbs, TV sets, radios, domestic appliances - have to be repaired or replaced frequently;
- for all national, regional or provincial cold stores, freezer stores or other cold chain equipment where large amounts of vaccine will be stored.

In addition to observing these effects of unreliable power supplies, the actual supply voltage at the point where cold chain equipment is used, or where an installation is planned should be measured by electrical technician. To confirm whether the supply is unreliable, the voltage must be measured at frequent intervals over as long a period as practicable, - several days at least, particularly when cuts are known to occur, or during mealtimes, etc, when many others may be using the supply. If measurements show a fluctuation of more than 10% above or below the expected standard voltage in the area, a voltage regulator is strongly recommended.

## How to select the correct voltage regulator ?

The technical specification for a voltage regulator will cover a number of features, but selection must be based initially on 4 important characteristics:

- nominal voltage,
- supply voltage range,
- output voltage range, and
- power rating

The **nominal voltage** is the electrical supply voltage measured in Volts (V) specified for the equipment which is to be protected. This may be, eg, 220 Volts, and the regulator selected must have a nominal voltage rated at this **same value**.

The **supply voltage range** defines the maximum and minimum supply voltage, eg, 145 - 275 V, for which the regulator can provide protection for the equipment. This range should be **greater than** the highest and lowest supply voltages measured at the point where cold chain equipment is used.

The **output voltage range** specifies the maximum and minimum voltages, eg, 200 - 225 V, which the regulator will pass on to the equipment it protects. This range should be **less than** the maximum and minimum permitted voltages stated by the equipment manufacturer.

The **power rating** is the load carrying capacity of the regulator, and is measured in Volt-Amps (VA), or in Watts (W) The power rating, usually specified as the continuous rating, eg 500 W continuous, must be **greater than** the power rating of the equipment to be protected. Power ratings for both cold chain equipment and regulators will be shown on data plates attached to an outer surface, usually on the back of a refrigerator or freezer, and on the top or underside for a voltage regulator.

---

Having made an initial selection of a regulator based on key technical specifications, other factors, such as time-delay protection against short-term high or low voltages, indicator lights to show operational status, cost, etc, may be considered.

### **3.2.6 “Ice lined” refrigerator**

This type of refrigerator is specially designed for vaccine storage and is different from a normal top-opening refrigerator. It can keep vaccine safe with as little as 8 hours electricity supply in a 24-hour period, and comes in various sizes for use at different levels in the cold chain. The design is top-opening because this type holds the cold air inside better than a refrigerator with a front-opening door. Inside the refrigerator, a lining of water containers (icepacks or tubes) are fitted around the walls and held in place by a frame. While the refrigerator is operating the water in the containers becomes frozen, and if the electricity supply fails, the lining of ice keeps the inside temperature of the refrigerator at a safe level for vaccines for much longer - usually for at least 2 days.

This type of refrigerator has a heavy-duty compressor, which will start at low voltages and continue to operate even if there are large variations in supply voltage.

**Figure 12: “Ice lined” refrigerator (Vestfrost MK 144)**

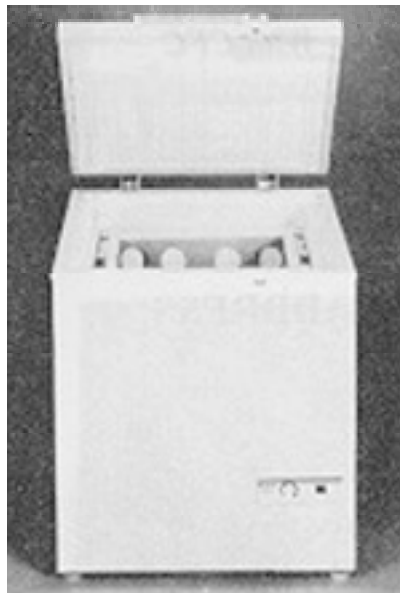

#### **Points for installation and use of “ice-lined” refrigerators**

- Install the lining of water containers completely according to the manufacturer’s instructions.
- After adjusting the thermostat, allow at least 24 hours for the temperature inside to change. This takes longer than a household refrigerator because of the “ice-lining”.
- Put BCG, mumps (and polio and measles vaccines if not kept in a separate freezer) in the bottom, where it is coldest.
- Put DPT, DT, Td and Hepatitis B vaccines in the baskets, nearer to the top. Do not put these vaccines within 15cm of the bottom of the compartment to avoid the risk of accidental freezing.

- In winter, or whenever the room temperature drops below +10°C, pay special attention to temperature checking, thermostat adjustment and the condition of these adsorbed vaccines. In these conditions the refrigerator may easily get too cold inside even with the thermostat at its warmest setting. Try to ensure that the room is heated. If not possible and the refrigerator cannot keep a safe temperature, move the vaccines to a cold box with water filled icepacks to help create a “warm chain” effect and keep the vaccines above freezing temperature. (see Section 3.1 above)

#### **SUMMARY POINTS!**

- At the regional level keep vaccines for a maximum of 3 months.
- Store OPV, measles & mumps vaccines in freezers at -15 to -25 °C.
- Store DPT, DT, Td, BCG & hepatitis B vaccines in refrigerators, preferably ice-lined, at 0 to +8 °C.
- Pay special attention to temperature checking in very cold weather.

#### **District level (i.e., at the Rayon SES)**

The following equipment is normally used at the district level:

- medium capacity top-opening or “ice-lined” refrigerators;
- medium capacity top-opening freezers;
- upright household two-compartment refrigerator/freezers (for use of household refrigerators see under HEALTH FACILITY LEVEL below).

#### **SUMMARY POINTS!**

- At the district level keep vaccines for a maximum of 1 month.
- Store OPV, measles and mumps vaccines in freezers at -15 to -25 °C.
- Store DPT, DT, Td, BCG and hepatitis B vaccines in refrigerators at 0 to +8 °C.

#### **Health facility level (i.e., at the SVA, SUB and FAP)**

One or more of the following types of equipment is normally used at the health facility level:

- small “ice-lined” refrigerators;
- upright household two-compartment refrigerators/freezers;
- small top-opening freezers

### 3.2.7 Household refrigerator

Although not specifically designed for the purpose, this type of refrigerator is often used for storage of vaccines. They are generally much cheaper to buy than purpose-made vaccine storage refrigerators, and can often be purchased in local currency. Various models of refrigerator are used, some having small freezing compartments located in the upper part of the main cabinet, and others having a separate freezer compartment. Household refrigerators are produced with 2 main cooling systems; absorption and compression types (see Fig. 13). The absorption type refrigerators derive their name from the process of absorption of refrigerant vapour, whereas in the compression type the refrigerant is caused to circulate by a compressor.

**Figure 13: Refrigerators:**  
**(A) compression type**

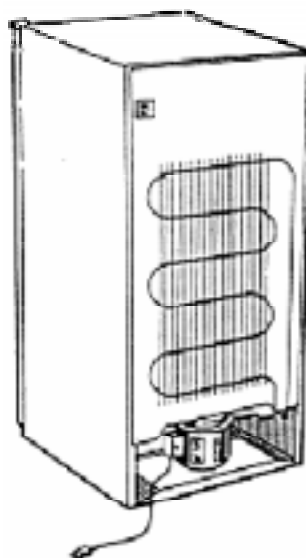

**(B) absorption type**



**Figure 13 (continued): Refrigerators:  
(C) absorption type**

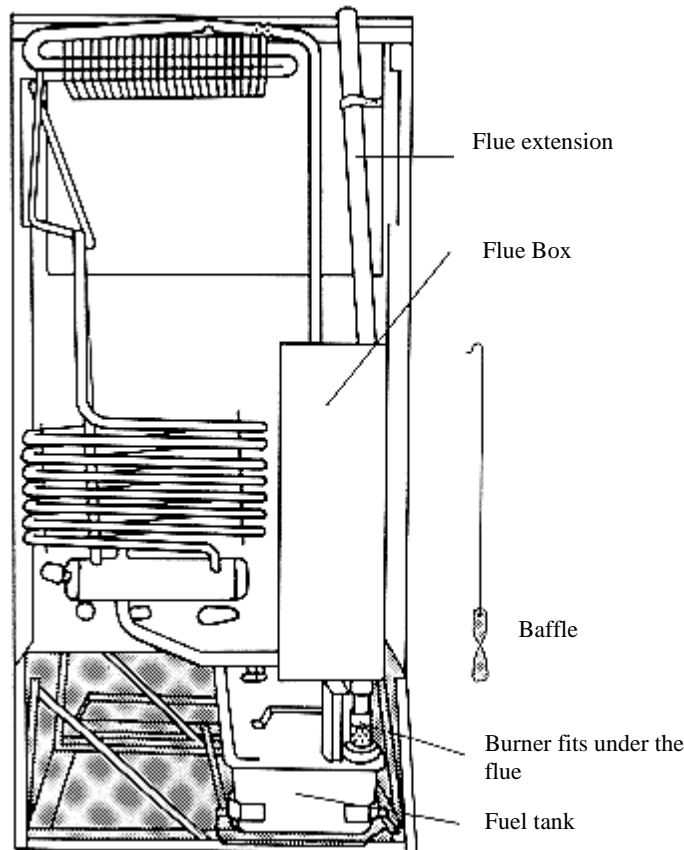

- A compression refrigerator is cheaper to buy and operate, but more expensive to maintain/repair. It cools faster and more efficiently than an absorption refrigerator, especially in very hot weather, but can only run on electricity.
- An absorption refrigerator is more expensive to buy and much more expensive to operate, but may be cheaper to maintain/repair because it has few moving parts. It cools more slowly and cannot cool as well as a compression refrigerator in very hot weather. However it can operate on any type of energy, including gas or kerosene as well as electricity.

#### **Points for installation and use for household refrigerators**

- At a health facility store all vaccines at 0 to +8°C in the refrigerator compartment. Use the freezer compartment only for freezing icepacks for vaccine carriers, use during immunization sessions, and for emergencies;
- always keep a thermometer in the refrigerator; read and record the temperature twice daily;
- store polio, measles and mumps vaccines closest to the evaporator and the adsorbed vaccines away from the evaporator to minimize the risk of freezing them; ( see **Figure 14** )

- 
- never store vaccines in the door shelves or the very bottom of the refrigerator, as both get warmer than the center of the compartment;
  - store vaccine boxes or trays with spaces between to allow air circulation inside the refrigerator;
  - rotate use of vaccine to ensure that the oldest are used first - use the “First In, First Out” system, unless the VVM on some polio vials shows that they should be used first, even if they have a later expiry date – (see section 5.5)
  - mark any partly used vials clearly, for first use next day/session. Do not keep reconstituted measles and BCG which must always be discarded at the end of the day;
  - fill the bottom of the refrigerator with water filled containers or spare water filled icepacks; these help keep a safe temperature for vaccine, especially when there is a power cut.
  - if diluent for measles and BCG vaccines is kept in the bottom, mark the respective vaccine and diluent boxes clearly so that those from the same manufacturer will be used together. This is particularly important if there are stocks of either of these vaccines from more than one manufacturer in the refrigerator at the same time.



Figure 14: Loading a household refrigerator (Russian version)



*Freezing compartment (top): ice packs, ice;*  
*Refrigerator First shelf: Live viral vaccines (polio, measles, etc.);*  
*Second shelf: BCG and other non-adsorbed vaccines, thermometer suspended;*  
*Third shelf: DPT and other adsorbed preparations, diluent, thermostat;*  
*Fourth/lowest shelf: water containers.*

#### **SUMMARY POINTS!**

- In health facilities, keep vaccines for a maximum of one month.
- Store all vaccines in the refrigerator at 0 to +8 ° C.
- Place OPV, measles and mumps vaccine closest to the evaporator.
- Place DPT, DT, Td, BCG and hepatitis B on lower shelves, away from the evaporator;
- Do not keep vaccines in the door shelves.
- Keep sealed water bottles in the bottom of the refrigerator.
- Keep diluent next to its vaccine or mark it clearly if it is placed on a different shelf.

---

# 4. Maintenance of cold chain equipment

The maintenance rules are essentially similar for all types of refrigeration equipment. Your equipment will show good performance only if you regularly clean it, defrost it and observe safety engineering rules.

## 4.1 Installation

Remember the following points when installing new or relocated equipment:

- Unpack carefully and inspect for any damage. If there is damage, notify the supplying office immediately;
- Check the data plate or the booklet enclosed to make sure that the voltage is correct (220-240V). Check also that the voltage stabilizer, if used, will provide the correct voltage;
- Correct location of equipment is important; normally use as cool a room as possible, with good ventilation, air circulation and away from direct heat or sunlight. In hot climates or seasons the room should have a fan, or even an air conditioner if there are two or more large refrigerators or freezers in the room;
- In very cold climates/seasons, the room might need to be heated in certain conditions;
- A low space around all equipment; place at least 20cm from the wall and at least 30 cm away from any other refrigerator or freezer beside it (many refrigerators and freezers give out heat at the sides and front as well as at the back);
- Make sure that nothing blocks the cover of the motor compartment, normally located at the back or the side of the equipment;
- Stand all equipment on level wooden blocks or a base at least 10cm high, and make sure each item is secure and will not move or shake when in use.

### **IMPORTANT!**

- The better the conditions in which the refrigerator or freezer is working (cool, dry and good air circulation), the longer will be the life of the equipment, especially the motor.

---

## 4.2 Defrosting

Frost and ice slowly build up on the surface of the freezing compartment (evaporator) while it is working. If this is allowed to become too thick, it prevents efficient cooling of the refrigerator compartment. Regular defrosting is therefore essential.

- A household refrigerator normally needs to be defrosted more frequently than a chest type refrigerator, but all refrigerators and all freezers and icepack freezers also need to be defrosted regularly;
- for all equipment, defrost when the frost layer reaches **5mm thick**;
- if you have to defrost more than once a month, the door seal may be faulty or the door may be being opened too frequently.

### Procedure for defrosting:

- remove the vaccine and store it in another working refrigerator or cold box with icepacks;
- switch off the refrigerator and pull out the plug;
- open the refrigerator and freezer doors;
- remove all icepacks from the freezer;
- if a chest type, open the drain plug at the bottom;
- put a bowl or tray in front or underneath to collect the ice and water;
- remove loose ice by hand only; no tools or sharp instruments to be used; the melting time can be reduced by putting a container with warm water (not over 50 degrees C) into the freezer;
- wipe the refrigerator dry and clean thoroughly;
- re-connect the power and turn the refrigerator on;
- wait until the refrigerator is again running at the correct temperature, and then replace the vaccines.

- |  |
|--|
| <ul style="list-style-type: none"><li>• <b>Do not</b> remove frost or ice with a knife or any other sharp instrument. These can easily cause damage to the refrigerator.</li></ul> |
|--|

## 4.3 Cleaning

### Refrigerators and freezers

Clean refrigerators and freezers after defrosting or every month, whichever is first;

- remove the vaccine and store it in another working refrigerator or cold box with icepacks;
- switch off the power and remove the plug;
- wash all the inside and shelves with warm, slightly soapy water, and dry carefully;
- once a month, remove dirt and dust from the condenser on the back of the refrigerator cabinet and from the motor, using a soft brush or a cloth. (On chest type refrigerators and freezers, the condenser is often inside the wall of the unit, and not accessible.);

- 
- if there is any rattling or other noise while the refrigerator is working, check any screws holding the condenser and if any tubes are vibrating or touching. If it continues, call a technician.

#### **Vaccine carriers and cold boxes**

- Clean the inner surfaces of all cold boxes after each working session;
- leave vaccine carriers open after cleaning so that they will be thoroughly dried;
- inspect the inner and outer surface for cracks. If these are found they should be mended immediately;
- if the cold box is fitted with adjustable locks, they should be adjusted so that the lid fits tightly;
- protect all carriers from direct sunlight, otherwise the plastic body may get warped or crack;
- handle all vaccine carriers and cold boxes with care and do not drop them.

### **4.4 Safety requirements**

Before switching on any item of electrical cold chain equipment, ask a qualified electrician to check all connections, plugs and switches. Do not attempt to make any connections yourself until you have been assured by the electrician that all equipment is safe and operating correctly.

If you ever feel electrical shocks when touching any metal part of your cold chain equipment or see signs of smoke or sparks coming from any electrical item, **TURN IT OFF IMMEDIATELY** and call an electrician.

Remember to switch off and disconnect your cold chain equipment whenever:

- it is being cleaned, whether inside or outside;
- any electrical item is being replaced;
- the refrigerator or freezer is being moved to another place;
- floors are being scrubbed under or near it.

If you expect the equipment to be disconnected for more than a few minutes, consider whether any vaccines stored need to be transferred to a cold box or another working refrigerator in order to maintain proper cold chain conditions.

#### **IMPORTANT!**

- A thick layer of ice on the evaporator surface hampers the work of the refrigerator.
- Defrost when the ice reaches 5 mm thick.
- When defrosting or cleaning put all vaccines into another refrigerator or cold box.

# 5. Control and monitoring of temperatures

Maintaining correct temperatures during storage and transport of vaccines is a critical task for the health worker. Temperatures must be regularly measured and recorded in order to:

- ensure storage of all vaccines at the correct temperature conditions, and
- ensure the correct operation of your cold chain equipment.

Monitoring of temperatures should be a routine activity, and a task that is carried out at the start and end of each working day. There are a number of different types of monitoring devices to help you measure, control and record storage temperatures.

## 5.1 Thermometers

Every piece of cold chain equipment must be fitted with a thermometer to measure the internal temperature at any given moment. If the refrigerator, freezer or cold box is not fitted with a thermometer, there is no way of telling if the vaccine is being stored at the right temperature and is maintaining its potency. The following types of thermometer are commonly used in the cold chain system to measure temperatures.

Figure 15: Common thermometer types

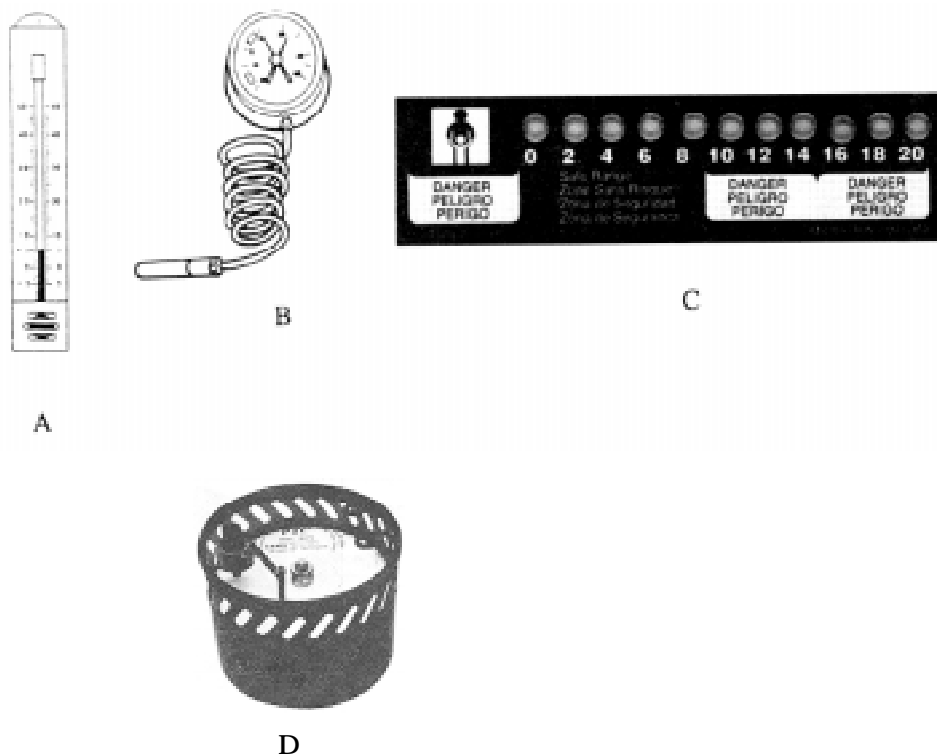

- 
- A. Alcohol or mercury thermometer: Shows precise temperatures in the immediate area of the sensing bulb. This is the recommended type for use with refrigerators or freezers.
  - B. Dial thermometer: shows the current temperature; a max/min version also shows the maximum and minimum temperatures since the previous resetting of the hands.
  - C. Liquid-crystal thermometer: Comprises a row of temperature-sensitive indicator spots; the spot corresponding to the current temperature changes to a bright green colour. This type of thermometer is suitable only for indicating the temperatures in cold boxes but is not for use in refrigerators.
  - D. Recording thermometer: This type records the temperature continuously on a paper chart, each chart typically recording for a period of 7 days. Recording thermometers are used mainly for cold rooms and freezing rooms. Note the date on each chart when it is fitted, and when you remove/change the chart, keep the old charts as a permanent record of store performance.

## 5.2 Temperature record sheets

- The person in charge of the cold chain equipment should read and note the temperature on the temperature record sheet twice daily: in the morning and in the afternoon. (see examples in **Annex 4**) In case of any malfunctions inform your supervisor. Each refrigerator/freezer must have its own temperature record sheet.
- In refrigerators/freezers use a recommended type of thermometer placed in the middle part of the main compartment of the refrigerator or freezer.
- In ice lined refrigerators it is preferable to have two thermometers; one placed near the bottom, and one near the lid. (Record both temperatures)
- In cold rooms and freezer rooms both a recording thermometer and an alcohol or mercury thermometer should be used. The thermometer and the sensors of the recording thermometer must not be placed in the airflow from the evaporator.

### REMEMBER!

- Keep all completed temperature record sheets in a file or safe place for future reference.

## 5.3 Refrigerator or freezer thermostats

Most refrigerators and freezers are fitted with a thermostat to control the storage temperature. The thermostat is adjustable so that the correct temperature may be obtained. Some thermostats have a scale or numbers on the control knob. These do not show temperatures, however, but levels of coldness - the higher the number the more cold, the lower the number the less cold.

If the temperature is too low you must decrease the amount of cooling. This is done by setting the thermostat to a warmer setting, i.e., turning the knob anti-clockwise. Some freezers have a fast freeze switch that overrides the thermostat. Ensure that it is turned off (*i.e., not lit up*) if the freezer is too cold.

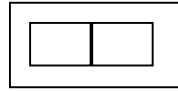
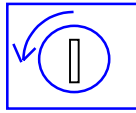

Fast freeze switch

Note that in very cold conditions, e.g., if the room temperature is below zero, adjusting the thermostat may not enable you to produce the correct storage temperature. In this case, your vaccines or refrigerator must be moved to a warmer place.

If the temperature in your refrigerator or freezer is too high you must increase the amount of cooling. This is done by setting the thermostat to a colder setting, i.e., turning the knob clockwise. Vaccine freezers are sometimes equipped with a red warning control light, which will show if the temperature is above  $-15^{\circ}\text{C}$ .

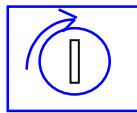

In very warm conditions e.g. if the ambient temperature is above  $40^{\circ}\text{C}$ , adjusting the thermostat to maximum cooling position may still not enable you to produce a low enough temperature. In this case, your vaccines or refrigerator must be moved to a cooler place.

If adjusting the thermostat does not enable you to produce the correct storage temperature, there may be something wrong with your refrigerator/freezer or the thermostat, and you must contact your supervisor. However, before calling the supervisor, consult the faultfinding checklists in **Section 8**.

## 5.4 Cold chain monitor card

A cold chain monitor card (CCM) is designed to follow the vaccines from the point of manufacturer to the end user. Throughout the journey the CCM monitors the temperature and will keep a record of vaccine exposures that have been experienced.

Vaccines delivered through UNICEF are shipped with one CCM per 3,000 doses of vaccines. The CCM has a temperature-sensitive indicator comprising 4 "windows" labelled A, B, C and D. There are spaces to record the vaccine type, manufacturer, shipment date, dates of receipt and dispatch, the name of health centre and indicator readings. There is also a table for interpreting its readings and user instructions. (see **Figure 16**)

The monitor is activated by removing a small protective strip, and after activation the indicator will show an irreversible colour change in one of the 4 "windows" if storage temperature rises above a certain level. (For imported vaccines, the CCM is activated by the vaccine manufacturer). The first three windows of the indicator (A, B and C) will change gradually and irreversibly from white to blue when temperatures are above  $10^{\circ}\text{C}$ . First A will change, then B and then C.

Figure 16: Cold chain monitor card, front and back

 КОНТРОЛЬНАЯ КАРТОЧКА-ИНДИКАТОР					
Дата поступления	Показания индикатора	Куда поступила вакцина	Дата отправления	Показания индикатора	
 3M MonitorMark™ Indicator		INDEX/INDEXE/ИД. 10°C 34°C  A B C D			
		Если «А» окрасилось полностью	Если «В» окрасилось полностью	Если «С» окрасилось полностью	Если «А», «В», «С» и «D» окрасилось полностью
Плиомиелитная вакцина	Используйте в течение 3 месяцев	<b>Не используйте вакцину до проведения контроля</b>			
Корь и красная лихорадка	Используйте в течение 3 месяцев				
АДС и БЦХ	Вакцина может быть использована	Используйте в течение 3 месяцев			
АС и АДС и Гепатит В					
ОТПРАВЛЕНО:		Тредирити-экспозитив Дата активации индикатора _____ Фамилия инициалы _____ 120 315			

Храните контрольную карточку-индикатор вместе с полученной вакциной.

Получив карточку-индикатор, сделайте соответствующие графы в ее верхней части:

- укажите дату поступления
- укажите, какой сектор индикатора полностью окрасился в синий цвет (А, В, С или D)
- укажите, куда поступила вакцина

Когда Вы отправите карточку индикатор, заполните соответствующие графы в ее верхней части:

- укажите дату отправления
- укажите, какой сектор индикатора полностью окрасился в синий цвет (А, В, С или D)

Если индикатор окрасился полностью, используйте вакцину как обычно.

Если секторы «А», «В» и «С» полностью окрасились, а «D» не окрасился, это значит, что вакцина хранилась при температуре выше + 10, но ниже + 24, в течение 3 месяцев хранения.

Температура хранения вакцины	Бонификационный индекс		
	A	AB	ABC
Температура хранения вакцины = 10	3 дня	6 дней	11 дней
Температура хранения вакцины = 21	2 дня	6 дней	11 дней

Если индикатор «D» окрасился в синий цвет, это значит, что вакцина хранилась при температуре + 34 и меньше двух часов или ДЦП был. Проверьте температуру хранения и транспортировки вакцины.

Проверьте срок годности вакцины, указанный на этикетке. Не используйте вакцину с истекшим или неполным обозначенным сроком годности.

Assembled & distributed by Berlinger Ganterschwil Switzerland

The A, B and C indicators change relatively slowly, for instance, at a temperature of 21° C window A changes its colour entirely in 2 days; window B, in 6 days and window C, in 11 days. If the temperature exceeds 34° C, window D changes in colour from white to blue also.

**REMEMBER!**

- The CCM is designed to follow the vaccine and keep a record of its heat exposure.
- Therefore, it must always be kept together with the vaccine batch with which it arrived.

**How to use the CCM card:**

On **receipt** of vaccines with a CCM, enter on the top part of the card:

- the date of receipt of vaccine, e.g., 19/07/95 if the vaccine arrived on July 19, 1995;
- the index (i.e., amount of blue) shown in the windows, (A,B,C and/or D)
- the name of your health facility e.g., "Alamudun Rayon SES ".

On **dispatch** of vaccines with a CCM, enter on the top part of the card:

- the date of dispatch of vaccine, e.g., 25/08/95 if the vaccine was sent on August 25, 1995;
- the index (i.e., amount of blue) shown in the windows, (A,B,C and/or D)



---

**How to interpret the CCM :**

- If windows A, B, C and D are all white, use vaccines normally.
- If windows A only, A and B, or A, B and C are completely blue, but window D is still white it means that the vaccine has been exposed to a temperature above +10°C but below 34°C for the number of days shown in Table 5.
- Follow instructions on card before using the vaccines.
- If window D is blue it means that there has been a break in the cold chain of a temperature higher than 34°C for a period of at least two hours. This would indicate a serious cold chain failure has occurred, and an immediate investigation is needed.

**Table 5: Time-temperature exposure of CCM card**

	Index		
Windows completely blue	A	AB	ABC
At a temperature of 12°C	3 days	8 days	14 days
At a temperature of 21°C	2 days	6 days	11 days

An example of a CCM card for a vaccine batch part way along the distribution system is shown in Figure 17.

Figure 17: Example of exposed CCM card

Дата поступления	Показание индикатора	Место поступления вакцины	Дата отправления	Показание индикатора
01/08/97	—	Центральный склад Ашгабад / Туркмения	04/09/97	—
05/09/97	—	Областная СЭС МАРЫ	20/10/97	A
21/10/97	A	Районная СЭС	19/11/97	A
19/11/97	AB	Поликлиника №2		

	INDEX/INDICE/دەرىجى	10°C	34°C
	A                  B                  C                  D		
	Если «А» окрасилось полностью	Если «В» окрасилось полностью	Если «С» окрасилось полностью
	Если «А», «В», «С» и «Д» окрасилось полностью		
Полиомиелитная вакцина	Используйте в течение 3 месяцев	Не используйте вакцину до проведения контроля	
Корь и желтая лихорадка	Используйте в течение 3 месяцев		
АКДС и БЦЖ	Вакцина может быть использована	Используйте в течение 3 месяцев	
АС и АДС и Гепатит В			

ОТПРАВЛЕНО: Предприятие-изготовитель: Институт сывороток Швейцария  
 Дата активации индикатора: 29/07/97  
 Наименование вакцины: АКДС

In this example, Index A and B are all blue, C and D are still white. That means that the Polio must be tested before use, the measles must be used within 3 months DPT & BCG and TT & DT can be used as normal.

The card also tells you that there is something wrong with the cold chain at the Pruta SES. The temperature has been e.g. 12°C for 8 days, as shown in Table 5.

**REMEMBER!**

- The CCM must always be kept with the vaccines with which it came.
- Follow your manager’s instruction on what to do with the CCM after the vaccines that it came with have been used.

## 5.5 Vaccine vial monitor

The vaccine vial monitor (VVM) is a new type of monitor device applied directly to each vaccine vial by the manufacturer. It enables the health worker to verify at the time of use, whether vaccine is in useable condition and has not lost its potency and efficacy due to temperature exposure. The VVM progressively changes colour with heat exposure, and gives a visual indication when exposure has occurred. The vaccine itself of course, exhibits no visible change with heat exposure. At present VVMs are only used on foreign-manufactured OPV, but similar

monitors are under development for other vaccines. All OPV supplied through UNICEF has been fitted with VVMs since mid-1996.

Note that VVMs are not a substitute for CCMs; they are an additional device to use in conjunction with other monitors.

Figure 18. How to read the VVM

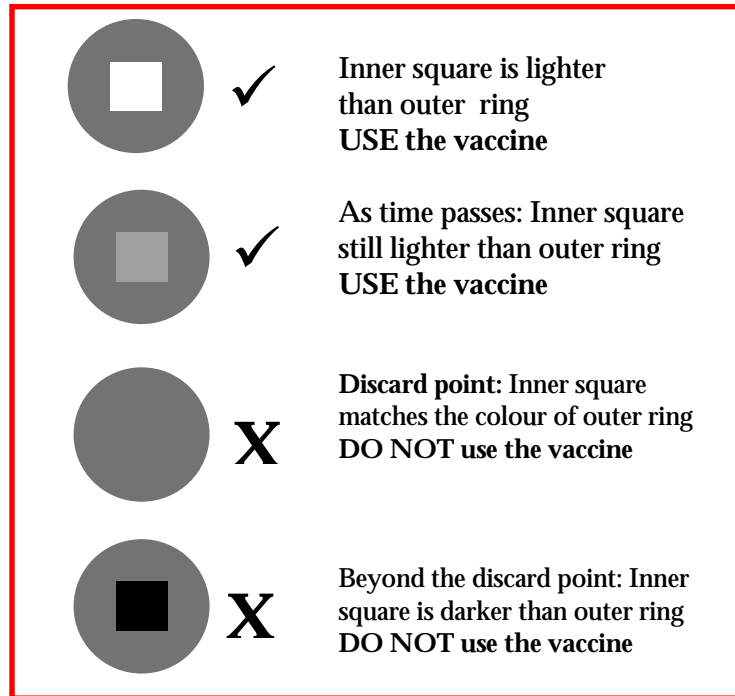

#### The benefits of using VVMs include:

- gives confidence for the reuse opened vials of vaccine; (only OPV at present) (see Policy on Vaccine Use, Section 1.6);
- potential for a large decrease in vaccine wastage;
- gives the health worker a positive indication that he/she is administering potent vaccine.

#### How does the VVM work?

The VVM has a heat sensitive square in a circular disk that registers a gradual and progressive colour change with exposure to heat. The inner square is initially white, but becomes darker with exposure to heat. All the time the inner square is lighter than the surrounding disk, the vaccine is safe to use. If the inner square becomes of equal colour or darker than the surrounding disk, the vaccine must NOT be used. (see Figure 18)

#### How to read the VVM:

The only important point is the colour of the inner square relative to the outer circle:

- If the inner square is lighter than the outer circle, the vaccine may be used.
- If the inner square is the same colour or darker than the outer circle, the vaccine must not be used.

A simple glance at the monitor will be enough to show whether the vaccine can be used or not.

**Table 6: Times recorded for a VVM attached to a vial of OPV**

<b>Constant temperature, day and night</b>	<b>Time for VVM to reach “discard point”</b>
At room temperature: +25°C	8 days
At room temperature: +20°C	20 days
In a refrigerator: +4°C	180 days
In a freezer: -20 C	over 2 years

### Questions and Answers on VVMs

- Q:** If the VVM has not reached “discard point”, can the vaccine still be used if it has passed its expiry date?
- A:** NO.
- Q:** If vials have a VVM, do they still need to be kept in the cold chain?
- A:** YES.
- Q:** Should other monitors, such as the Freeze Watch or CCM still be used?
- A:** YES.
- Q:** If the information provided by a CCM differs from the information of the VVM, which reading is the more accurate?
- A:** THE VVM, FOR THE INDIVIDUAL VIAL. (see Section 5.5.4)
- Q:** Is there a limit to the number of times a vial can be taken for outreach (or used in NIDs)?
- A:** NO, not as long as the VVM is still a safe colour and the expiry date has not passed.
- Q:** Will vaccine with partially darkened VVM be handled differently?
- A:** YES, Vaccine with darker VVMs must be selected for distribution first. The VVM enables the health worker/storekeeper to pick out vaccines for use on the basis of most exposed vials rather than “first in, first out”.

### How does information from a VVM relate to that given by a CCM?

- The CCM indicates when temperature limits of the cold chain have been passed.
- The VVM takes the monitoring procedure one step further and shows the impact of any such temperature changes on each individual vial of vaccine.
- The CCM monitors “the vaccine’s journey”, while the VVM shows how each “vaccine passenger” has fared.

**NOTE:**

- The VVM is not affected by freezing temperatures so it cannot give any information about freezing.

## 5.6 DT & TT vaccine shipping indicators

This is another type of indicator, which travels with the vaccines from manufacturer to Central Store and is included with each 3,000 doses of DT, DPT and TT procured through UNICEF.

This indicator has a temperature sensitive dot that irreversibly change from silver-gray to black at temperatures above +48°C, temperatures which may be reached if vaccines are left in the sun or in poorly ventilated places.

Figure 19: DT/TT shipping indicator

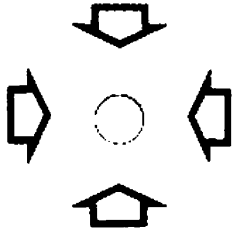
 <p><b>Td, DT AND TT VACCINE SHIPPING INDICATOR</b> <b>INDICATEUR POUR LES ENVOIS DE VACCINS DT ET ANTITÉTANIQUE</b> <b>INDICADOR PARA LOS ENVIOS DE VACUNAS DT Y ANTITETANICA</b> <b>ПОКАЗАТЕЛЬ ДЛЯ ПЕРЕВОЗКИ ВАКЦИНЫ АДС И АДС-М И СТОЛБНЯЧОЙ ВАКЦИНЫ (АС)</b></p> <hr/> <p><b>CAUTION:</b> IF GREY DOT TURNS BLACK, DO NOT USE VACCINE</p> <p><b>AVISO:</b> SI EL CIRCULO GRIS SE VUELVE NEGRO NO UTILIZAR LA VACUNA</p>  <p><b>ATTENTION:</b> SI LA PASTILLE GRISE VIRE AU NOIR NE PAS UTILISER LE VACCIN</p> <p><b>ВНИМАНИЕ:</b> ЕСЛИ СЕРЫЙ КРУГ СТАНОВИТСЯ ЧЕРНЫМ, НЕ ПРИМЕНЯЙТЕ ВАКЦИНУ</p>	<p>WHO recommends that diphtheria-tetanus and tetanus toxoid vaccines should be stored at temperatures between 0°C and + 8°C at all times. During international shipments it is recognised that this temperature range is not always maintained. In the event that diphtheria-tetanus and tetanus toxoid vaccines are exposed to temperatures of + 48°C, they are destroyed and should not be used.</p> <p><i>This card should be included with all international shipments of diphtheria-tetanus and tetanus toxoid vaccines. The grey dot on the other side of this card changes colour to black at 48°C.</i></p> <p><b>CHECK THE COLOUR OF THE DOT ON THE OTHER SIDE OF THIS CARD.</b></p> <p>ВОЗ рекомендует постоянно хранить дифтерийно-столбнячную и АДС-м и столбнячную анатоксинальную вакцины при температуре от 0°C до + 8°C. Известно, что во время международных перевозок не всегда поддерживается этот температурный режим. В случае, если дифтерийно-столбнячная и столбнячная анатоксинальная вакцины подвергаются воздействию температуры + 48°C, они разрушаются и их не следует применять.</p> <p><i>Эту карту следует включать в сопроводительную документацию по всем международным перевозкам дифтерийно-столбнячной и столбнячной анатоксинальной вакцин. Серый круг на другой стороне этой карты превращается в черный при температуре + 48°C.</i></p> <p><b>ПРОВЕРЬТЕ ЦВЕТ КРУГА НА ДРУГОЙ СТОРОНЕ ЭТОЙ КАРТЫ!</b></p> <p><small>Assembled &amp; distributed by Beringer Ingelheim Switzerland</small></p>
--	--

**REMEMBER!**

- If the dot has turned black, do not use the vaccines.

## 5.7 FreezeWatch indicator

The FreezeWatch indicator is an irreversible temperature indicator, which shows if vaccines have been exposed to temperatures below 0°C. It consists of a white backing card with a small vial of red liquid, all contained in a plastic casing. If the indicator is exposed to temperatures below 0°C for more than one hour, the vial will burst and release the red liquid. The indicator is used to monitor the storage conditions of DPT, DT, Td, TT and Hep. B. vaccines that lose their potency if frozen. (FreezeWatch indicators supplied before 1997 burst at -4°C; the design was changed because Hepatitis B vaccine freezes at -0.5°C)

Figure 20, on the left image, shows the indicator with an intact vial, and the right image shows the indicator with a burst vial. Changes in the colour of the paper are irreversible and will be clearly seen.

Figure 20: FreezeWatch indicators inactivated and activated

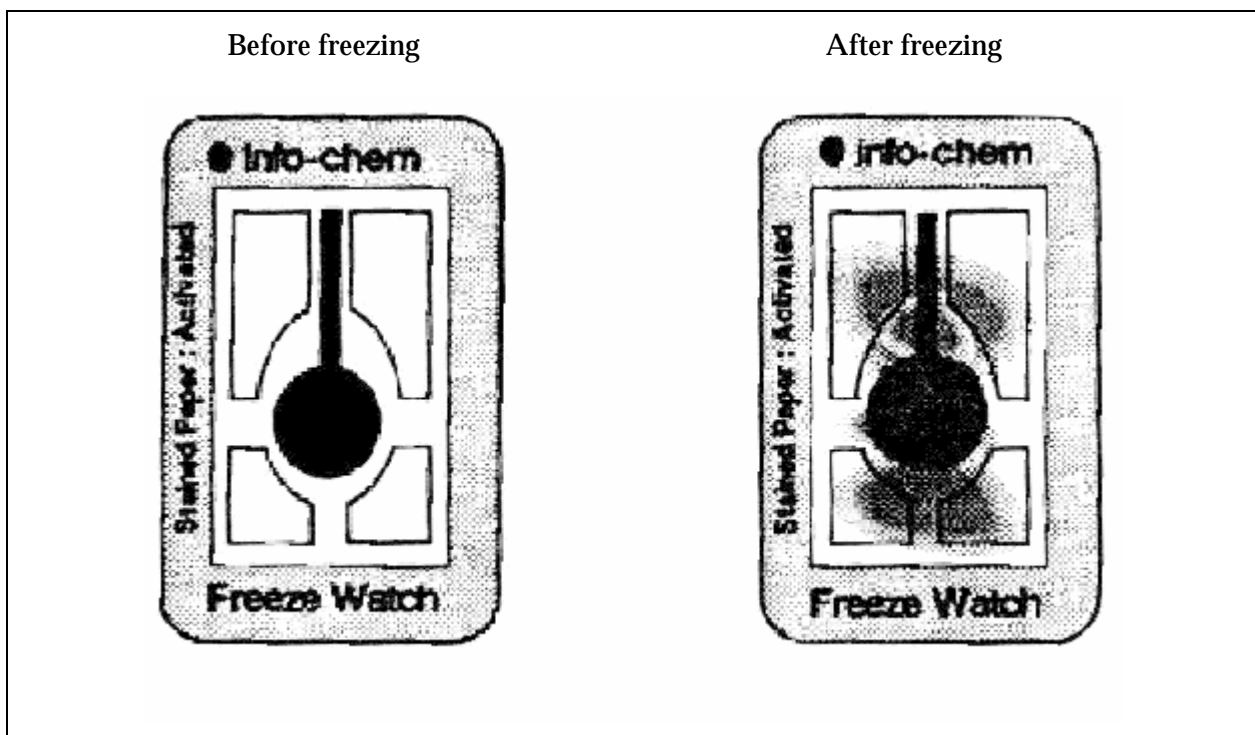

### WARNING!

- If a FreezeWatch indicator has burst, the vaccines it accompanied should be checked before use.

## 5.8 Stop!Watch indicator

This is an indicator for monitoring the operating conditions in a specific refrigerator, instead of traveling with the vaccine. It comprises a card onto which a CCM and a FreezeWatch indicator are combined to monitor both the upper and the lower storage temperatures occurring in the refrigerator (figure 21).

Figure 21: STOP!Watch refrigerator monitor



Used as a supervisory tool or as an aid for the health worker, the monitor is used as follows:

- (1) Activate the CCM by removing the protective strip and place the Stop!Watch indicator in the refrigerator.
- (2) The monitor will keep a separate check on the temperatures in the refrigerator, both high and low. It is not a substitute for the thermometer and temperature record sheet however, and records must still be kept regularly.
- (3) Check the Stop!Watch daily when the thermometer is read. If any change occurs in the index of the of the CCM or the condition of the Freezewatch indicator, note it on the back of the Stop!Watch and inform your supervisor. Check the operation of the refrigerator and check the condition of the vaccine.

## 5.9 Vaccine shake test

This test is designed to determine whether adsorbed vaccines (DPT, DT, Td, TT or hepatitis B) have been frozen. After freezing, the vaccine is no longer a uniform cloudy liquid, but tends to form flakes. Sedimentation occurs faster in a vaccine vial which has been frozen than in a vaccine vial from the same manufacturer which was never frozen.

The shake test is most easily demonstrated using a vaccine vial that you personally froze and do not intend to use for immunization. This vial can be used as a “frozen control sample” to be compared with suspect vaccines. If the control vial shows much faster sedimentation than in the vial being tested, the vaccine in question is *probably* potent and may be used. If, however, the sedimentation rate is similar and contains flakes, the vial under test should not be used. It is important that the shake test is done using both "tested" and "control" vaccine vials produced by the same manufacturer.

**Test procedure:**

- Take both vials, shake vigorously for 10-15 seconds.
- Leave vials at rest for 5-10 minutes.
- View vials against the light.
- Compare with Figure 22.

**Figure 22: The vaccine shake test**

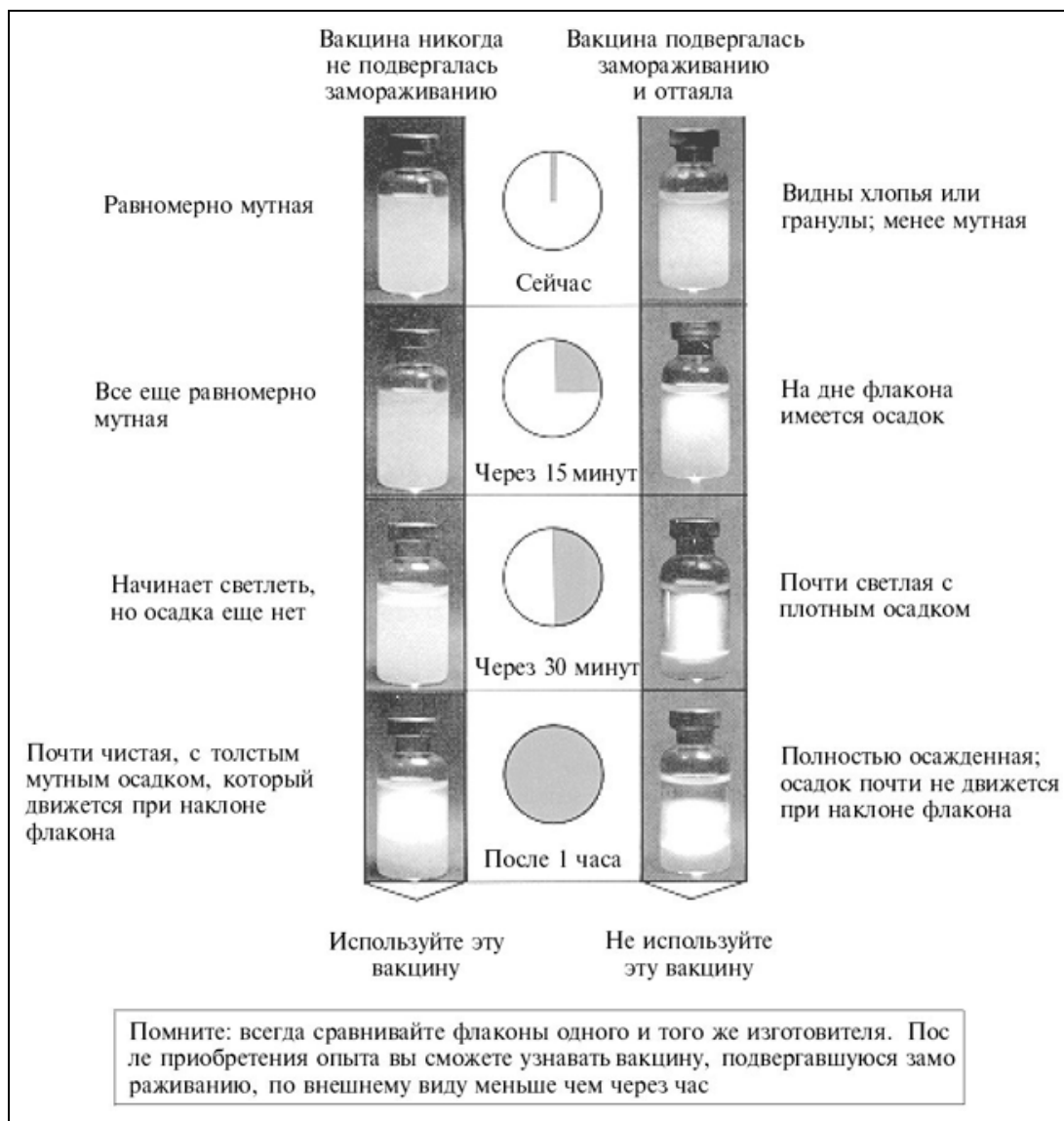

**Note:**

- (A) Vaccine was not frozen - use this vaccine.
  - (B) (Control) vaccine was frozen and thawed - do not use this vaccine.
- If the vial being tested looks the same as (B), do not use it!!



---

# 6. The cold chain during immunization sessions

Maintaining the cold chain during immunization sessions is the last, vital step to ensure that potent vaccine reaches its destination - the child. Vaccines are at their most vulnerable at this level because all vials have to be opened, freeze-dried vaccines have to be re-constituted, and health staff must handle each vial many times. Thus, the health worker conducting immunization sessions has a special responsibility to take care of vaccines and maintain the last and most important link of the cold chain.

The following rules will help you to ensure safe vaccines and effective immunization:

## 6.1 At the beginning of the working day

- Check the refrigerator temperature and enter details on the record sheet. If the temperature needs adjustment, take necessary steps as described in **Section 5.3**;
- check your attendance register and estimate how many vials of each vaccine will be needed during the planned immunization session;
- prepare a vaccine carrier for this number of vials, and add icepacks sufficient to last throughout the planned session. Do not work directly from your refrigerator, as this could involve frequent opening of the door;
- place new, unfrozen icepacks in the freezer ready for the next working day, on their edge so that each icepack is in contact with the evaporator (see **Figure 14**) (Remember, icepacks take at least 24hrs to become completely frozen);
- take the required quantity of vaccine and diluent from the refrigerator and place in the vaccine carrier, making sure that the diluent exactly matches the vaccine it came with (same manufacturer and delivery). If you cannot read the details of the diluent, do not use it.

## 6.2 During immunization sessions at fixed health facilities

- Take vials from the vaccine carrier and open or re-constitute them ONLY after calling the first child for immunization;
- take a fresh vial out of the vaccine carrier only when the previous one is empty;
- administer the vaccine and put vials with the remaining vaccine back into the vaccine carrier as QUICKLY as possible; Use the foam pad in the top of the vaccine carrier, wherever available, to keep vials you are using both cool and safely upright (see **Section 3.1.2** and **Figure 23**);
- vials containing absorbed vaccines (DPT, DT, Td and TT) must be shaken well before use;

Figure 23: Foam pad with vials in top of vaccine carrier

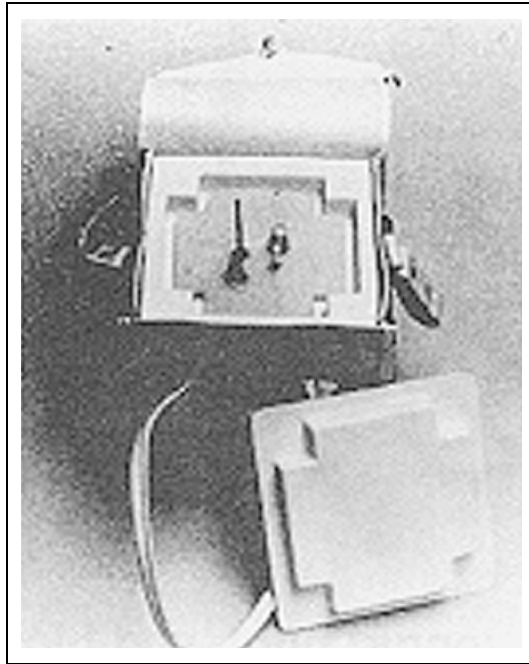

- for measles and BCG vaccines, using the ENTIRE volume of the cooled diluent supplied when re-constituting; use ONLY the diluent supplied by the vaccine manufacturer for use with that vaccine, and ensure that it is as cool as the vaccine;
- always keep the dropper for OPV attached to the vial. Use ONLY the dropper supplied and give the correct number of drops for that particular vaccine. ONLY administer the vaccine orally. OPV must NEVER be injected;
- while they are outside the vaccine carrier, keep all vaccines out of direct sunlight and away from other sources of heat. Avoid handling them any more than absolutely necessary.

### 6.3 At the end of the working day:

- If your Ministry has adopted the “Opened Vial Policy” for vaccines, opened vials of OPV, DPT, DT, Td, TT and hepatitis B should be returned to the refrigerator for use during the next session. **Opened vials of measles and BCG, however, must still be discarded as usual.** If your Ministry does NOT yet follow this policy, ALL remaining open vials or ampoules must be discarded, irrespective of the amount of vaccine remaining in them;
- discard all used syringes and needles SAFELY, and in accordance with instructions from your Ministry;
- put all unopened vials back into the refrigerator CLEARLY IDENTIFIED so that they will be used FIRST during the next session. For this purpose, you might place them in a box or tray with an inscription: "FIRST PRIORITY" so that you remember which vials have already been outside the refrigerator;
- record the quantity of vaccine used during the session and take the stock of the quantity of each vaccine you have left (remember to record this in doses);
- check the refrigerator temperature and enter details on the record sheet.

**IMPORTANT:**

- Most “adverse events following immunization” (AEFI) are found by who to be related to errors in practice (i.e., errors in storage, handling or administration of vaccines).
- Annex 5 shows a list of common errors. Study this list carefully, and make sure that none of these errors occur during your immunization sessions.

## 6.4 During outreach immunization sessions

Most of the points outlined above for immunization at fixed health facilities also apply during outreach immunization sessions. However, some additional points should be remembered:

- plan the session carefully, and especially check that you take a sufficient stock of vaccine and diluent. You cannot easily return for more if you run out;
- also take sufficient icepacks. Again, it will be difficult to find extra ice while you are working in the outreach area;
- for long outreach sessions where you need to travel for several days in areas where there is no electric power supply or refrigerator, take an EXTRA COLD BOX containing extra icepacks. Those in the vaccine carrier can then be replaced if they begin to melt, and safety of the vaccine can be assured;
- if outreach immunization sessions have to be conducted outdoors, choose a cool site, shaded from the sun throughout the day wherever possible.

**SUMMARY:**

- Use a vaccine carrier to keep vials needed for each session. Do not work directly from the refrigerator.
- Remember that vaccines are especially vulnerable at this level. Keep them between 0 and +8 °C at all times.
- Use opened vials, or those which have already been kept outside the refrigerator first during the subsequent immunization sessions.
- If DPT, DT, Td or hepatitis B vaccines are suspected to have been frozen, do not use them. Check first with shake test (see section 5.8)
- For reconstituted vaccines, use only the diluent supplied by the vaccine manufacturer.
- Any reconstituted vaccine must be discarded after 6 hours.
- All used syringes and needles must be disposed of safely.

# 7. Syringes, needles and sterilisation

Ensuring safe immunizations extends right to the place and time that the vaccine is administered during an immunization session. Correct use and care of injection equipment is therefore just as important as safe vaccine handling and maintaining the cold chain.

## 7.1 Injection equipment

Injection equipment can be divided into four categories:

- reusable syringes and needles
- disposable syringes and needles
- single use syringes (the “auto destruct” system)
- syringes without needles (jet injectors)

### 7.1.1 Reusable syringes and needles

These are glass or tough plastic syringes with steel needles. Immediately after each and every use, the needles and syringes *must* be rinsed and then sterilized in a steam sterilizer for 20 minutes at a temperature of 121 - 126 °C. Boiling is not an effective means of sterilisation because the temperature reaches only 100° C at most, and does not destroy all microorganisms. The reusable needle can be used for up to 50 injections and the reusable syringe for 50-200 injections, depending on the hardness of the water used in sterilisation. In hard water areas, the numbers of uses and re-sterilisations possible may be much less than this unless a “hard water pad” (a water softening device) is used in the steriliser.

For all sterilisations, a special indicator called a “TST” indicator should be used to show whether or not full sterilisation has taken place. (see Section 7.2.1)

Figure 24: Reusable syringes and needles

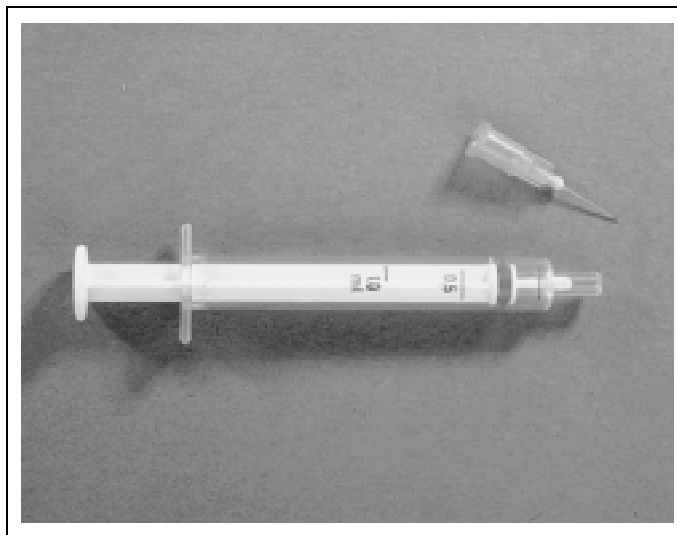

### 7.1.2 Disposable syringes and needles

Disposable syringes are sterilised during manufacture, then packed and their sterility is assured until the expiry date on the packet. Disposable syringes are for **SINGLE USE ONLY**, after which they must be disposed of safely. Burning at a high temperature is the most effective way to dispose of used injection equipment, to prevent reuse and to avoid hazards to staff and environment.

Figure 25: Disposable syringes and needles

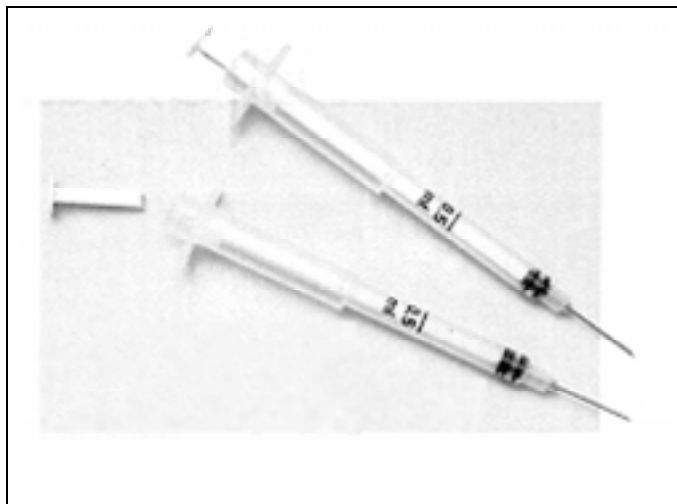

### 7.1.3 Single-use syringes (the “auto-destruct” system)

Single use “auto-destruct” syringes have a special mechanism which locks the piston after one movement and automatically prevents reuse. These are available in 0.5 ml and 0.05 ml sizes to suit all EPI immunizations.

During production the needle is joined to the syringe, which are then sterilized together and packed individually. The syringe/needles are packed in special containers which can be used as incinerators for the quick destruction of the used injection equipment, known as “safety boxes”.

This type of syringe presents the lowest risk of person to person transmission of bloodborne pathogens because it cannot be reused. The auto destruct syringe is the preferred type of disposable equipment for administering vaccines, and is the equipment of choice for conducting mass immunization campaigns.

Figure 26: “Auto-destruct” syringe

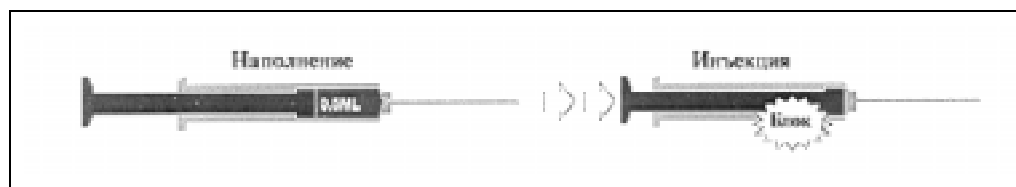

### 7.1.4 Jet injector gun

Jet injector guns do not have needles. Immunization is achieved by a liquid stream penetrating the skin under high pressure created by a hydraulic or mechanical system.

Jet injector guns were originally developed for high workload situations and were used for many years in mass immunization campaigns. The development of models for low workload situations may soon make jet injector guns available for use in small health facilities. This type could be loaded by hand (whereas a compressor is needed for high workload injectors) and will be rated at 20,000 injections at least. At present, some countries do not permit the use of jet injector guns because of the fear of cross infection with organisms such as Hepatitis B or HIV.

Figure 27: Jet injector gun

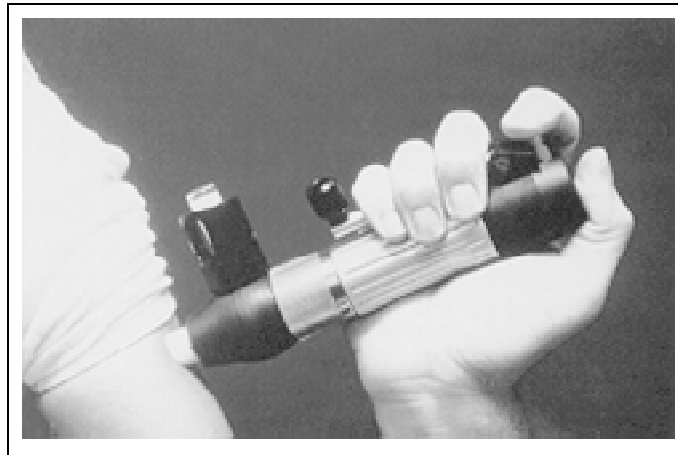

## 7.2 Sterility and sterilisation of reusable equipment

Sterility means the absence of all microorganisms (bacteria, viruses). Syringes and needles must be sterile before use for injections in order not to infect the human body.

Microorganisms are everywhere: in the air, on a table, on the floor, on your hands, in your nose or mouth, on the skin and on everything that has not been sterilized. As soon as you touch sterile equipment, use it or put it on a table, it becomes unsterile or infected. The only way to ensure sterile reusable equipment, and the only method recommended by WHO, is by steam processing for 20 minutes at a temperature of +121 - +126°C in a steam steriliser. Many countries use portable steam sterilisers in immunization programmes; these work under high pressure and look like steam pressure cookers. (see Figure 28) If you don't have a steam steriliser you can boil equipment in a steam pressure cooker which produces a high pressure and temperature while boiling. However, it is still essential that the temperature reaches +121 - +126°C, and is maintained for at least 20 minutes. Whichever method is used however, all injection equipment must be washed before sterilisation.

Figure 28: Steam steriliser: (A) Single rack; (B) Double rack

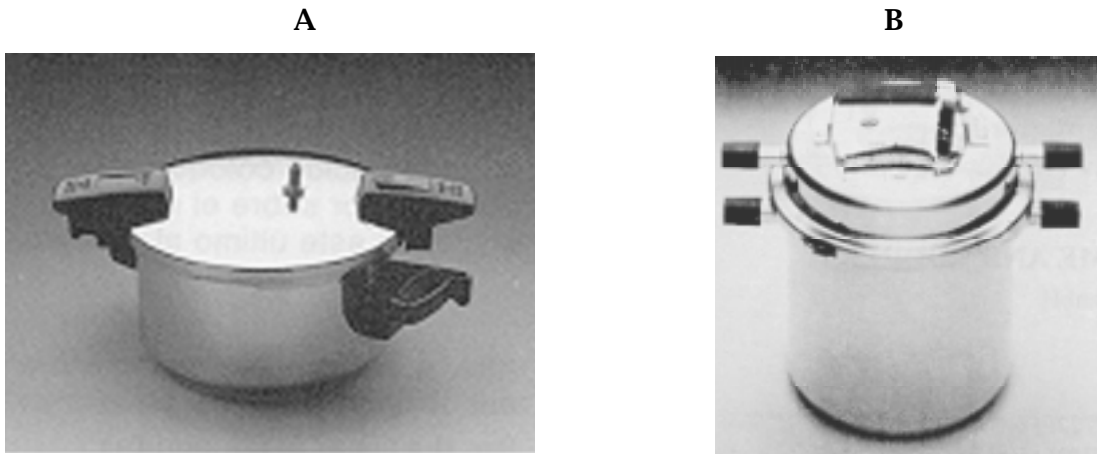

**REMEMBER:**

- Use a single sterile syringe and single sterile needle for every injection.
- Discard all used syringes and needles in a “safety box”.

### 7.3 Confirming complete sterilization

For all sterilisations, it is important to ensure that complete and effective sterility has been obtained, and that the process has achieved the minimum temperature required of +121 - +126 °C for a period of at least 20 minutes. A special monitor device called a “TST indicator” is available for this purpose. (see Figure 29) This comprises a small strip which is placed inside the steam steriliser at the beginning of the sterilizing cycle, and which shows an irreversible colour change once the required temperature and time have been reached. On completion of the sterilisation cycle, the health worker opens the steriliser and checks that the TST indicator has changed colour. If so, this is positive assurance that the contents of the steriliser have been 100% sterilized.

Figure 29: TST indicator



---

### Important points during steam sterilisation:

The WHO document “Safety of injections in immunization programmes” gives a full description of recommended policy and practice on this subject. Also, the WHO manual for health workers “Immunization in Practice” gives detailed recommendations on how to use injection equipment on sterilisation, and how to use a steam steriliser. These documents emphasize the following important points:

- ALWAYS have a sufficient quantity of syringes and needles; one sterile syringe and sterile needle must be used for EVERY injection.
- Only REUSABLE equipment should be sterilised; disposable equipment is produced sterile, but cannot be re-sterilized.
- When using disposable equipment, check carefully that the packet is intact and the expiry date has not passed. If the packet is damaged or expired, do not use the equipment; but make sure that it is destroyed.
- Boiling was previously used as a method of sterilisation. It is simpler, but the temperature reaches only +100° C and does not guarantee to destroy all microorganisms, for example the tetanus spore. At altitudes above sea level, water boils at less than 100° C, which makes it even more difficult to achieve sterilisation. At present, steam sterilisation is the only way of sterilisation.
- All injection equipment must be washed before sterilisation. Blood, serum or vaccine particles can remain in the equipment, specifically inside the needle or the sides of the syringe barrel or in the hub, and are not destroyed by sterilisation. This is why all equipment must be washed thoroughly to remove such particles before they dry.

### When and where to sterilize injection equipment:

Depending on the situation, sterilisation can be done:

- at the polyclinic before immunization begins, or before the outreach team departs;
- during the immunization session, or
- at the polyclinic after the immunization session has ended.

The best option is to wash and sterilize equipment in a polyclinic immediately after immunizations; then you will have everything ready for the next immunizations session or the next outreach clinic;

If this is not possible, the next best alternative is to wash instruments immediately after immunizations end, and prepare them for sterilisation. Sterilize the following morning before immunizations begin, or in periods between preparing vaccines and other necessary equipment;

Finally, if you have insufficient syringes and needles for all immunizations, the only remaining alternative is to wash and sterilize the necessary quantity during immunization. Remember that instruments must be sterilized for 20 minutes and must get cold before you start to use them. If you have insufficient syringes and needles, discuss the problem with your supervisor and ask if more can be provided.



---

**Always** observe the following simple rules for safe immunizations:

- wash your hands before each injection;
- keep equipment in a closed sterile container;
- use sterile pincers to take equipment out of the container;
- don't take equipment out of the container by hand; if you do, you infect all instruments;
- sterilize pincers together with syringes and keep pincers on a sterile tray or in a sterile container;
- to prevent contamination, don't lay out sterile syringes on the table;
- if you need to put down a syringe before you finish using it, put it on a sterile tray.

**REMEMBER!**

- Never sterilize disposable equipment;
- Never sterilize equipment which has not been washed thoroughly;
- Always let sterilized syringes and needles cool completely before using with vaccine.

---

# 8. Breakdowns and emergencies

Any interruption to the normal functioning of cold chain equipment must be considered an emergency. Your vaccine is in danger, and unless action is taken QUICKLY there is a risk of damage or complete loss of the vaccine stock. Emergencies in the cold chain occur mainly due to technical faults in the refrigerator, or to power failures, but whatever the cause, they can seriously disrupt planned immunization activities. The risks can be minimized however, if emergencies are anticipated and backup plans prepared in advance.

## 8.1 Technical faults in the refrigerator

There are a number of possible faults which may occur in the refrigerator, some simple and easily corrected by the user but others more complex and requiring the attention of a technician. The following checklists will help you to identify the main problem when a cold chain problem occurs, and give guidance on how the problem may be resolved. This should help to minimize the risks to your vaccine stocks.

How do you know what kind of technical fault exists in your refrigerator?

**There are 4 main symptoms of a fault:**

- the refrigerator will not start, and there is no cooling at all; or
- the vaccine storage temperature is too high (above +8 degrees C); or
- the vaccine storage temperature is too low (below 0 degrees C); or
- the refrigerator is working, but is making excessive noise.

For each of these 4 main symptoms, the following CHECKLISTS will help you to understand more exactly what is wrong, and what to do. There is one checklist for each main symptom.

How to use the checklists:

**Step 1** - decide which of the 4 main symptoms best describes the fault.

**Step 2** - turn to the appropriate checklist and read the first “CHECK” question in the left column. Answer the question with Yes or No. The arrows on the checklist show you what to do next:

- if you answered Yes, this was not the fault, and you must proceed down the “CHECK” column to the next question.
- If you answered No, you have identified a fault. Follow the arrow across to the “DO” column, which tells you how to correct the fault found.

**Step 3** - continue in this manner, beginning at the first question and continuing to the last. However, before passing on to the next question MAKE SURE that no fault exists in the function you are checking. It is easy to overlook simple details when you are trying to solve a cold chain failure as quickly as possible.

---

**Step 4** - for each question, follow strictly the sequence of actions recommended. Do not jump from one check to another, as this leads to wrong fault diagnosis.

**Step 5** - If you reach the last question with all YES answers and the refrigerator is still not working properly, you may have missed some important detail. Therefore, go back to the first question and REPEAT all again, this time making QUITE SURE that no fault exists in each of the functions you are checking.

**Step 6** - If after repeating all questions on the checklist no fault has been identified, protect the vaccine AS QUICKLY AS POSSIBLE by:

- transferring the vaccines to a refrigerator at 0 to +8° C or to a cold box;
- call a cold chain technician to examine the faulty refrigerator.

**CHECKLIST 1:  
The refrigerator will not start & there is no cooling at all**

CHECK	DO
1. Is the refrigerator plugged in? <b>YES</b>	If NO: Plug refrigerator in.
2. Is thermostat set in operative position? <b>YES</b>	If NO: Set thermostat in operative position.
3. Do other electrical appliances work if connected to the refrigerator's socket? <b>YES</b>	If NO: Check wiring and socket; if possible, plug refrigerator in at another socket.
4. Has plug been fitted correctly? <b>YES</b>	If NO: Correct plug fault.
5. Is there a 'click' when thermostat is set in operative position? <b>YES</b>	If NO: Check thermostat.
6. <b>Call in mechanic; refrigerator in serious trouble.</b>	

**CHECKLIST 2:  
The vaccine storage temperature is too high (above +8 degrees C)**

CHECK	DO
1) Is control set at correct temperature? <b>YES</b>	If NO: Set thermostat control at cooler temperature.
2) Are evaporator walls free from snow layer? <b>YES</b>	If NO: Turn off refrigerator and defrost.
3) Is refrigerator door tightly closed? <b>YES</b>	If NO: Check seal, adjust hinges and lock.
4) Is air circulating freely inside and outside refrigerator? <b>YES</b>	If NO: Install and load refrigerator properly.
5) Is condenser clean? <b>YES</b>	If NO: Clean condenser using brush or vacuum.
6. Is thermostat working properly? <b>YES</b>	If NO: Close circuit without using thermostat.
7. <b>Call in mechanic.</b>	

**CHECKLIST 3:**  
**The vaccine storage temperature is too low (below 0 degrees C)**

CHECK	DO
1. Has thermostat control been set at correct temperature? <b>YES</b>	If NO: Set thermostat control at warmer temperature.
2. <b>Call in mechanic.</b>	

**CHECKLIST 4:**  
**The refrigerator is working, but is making excessive noise**

CHECK	DO
1. Are there any foreign noises?	If YES: Shake refrigerator carefully. If it is insecure, stand it evenly, using wooden blocks. If noise continues, check metal parts on back of the cabinet; if trouble persists, <b>call a mechanic.</b>

## 8.2 Plan for cold chain emergencies

Emergencies are sure to happen from time to time, however well you manage your programme, so prepare for these emergencies **BEFORE** they happen. An emergency plan to ensure maintenance of the cold chain should be prepared for each vaccine storage point and for vaccines during transportation. (refer to Section 8.2.1) The plan should be prepared by the person responsible for the store or transport arrangements, and agreed with his or her supervisor.

The plan should include:

- **What to do to protect the vaccines ?**
- **How to correct the faults most quickly ?**

Important points to remember during any cold chain emergency:

- Keep all refrigerators, freezers and cold boxes **CLOSED** as far as possible. Only open when absolutely essential, and work as quickly as possible.
- Vaccines can be stored in domestic refrigerators without power for approximately 2 hours (the more water containers at the bottom, the longer), provided that the doors are kept closed.
- Vaccines in freezers are normally safe for up to 24 hours or until any icepacks or ice has melted.
- Vaccines in ice-lined refrigerators or freezers will be safe for much longer, and depending on which model is used, can be protected for up to 48 hours.

- 
- If a power failure lasts longer than 2 hours, vaccine should be TRANSFERRED from domestic refrigerators to a cold box with adequate icepacks. Upon resumption of power supply, do not return vaccines to the refrigerator until proper storage temperatures are restored (i.e., 0 to + 8 ° C). Remember that some vaccines are much more sensitive to heat than others (see Section 1.4); give them priority when making alternative storage arrangements in an emergency.

### ***8.2.1 Sample plan of emergency measures***

#### **A. General**

##### ***Objectives of an Immunization Program Emergency Plan***

- 1) To keep vaccines safe.
- 2) To keep immunization activities going.

##### ***Principles***

- 1) Be prepared for "emergencies."
- 2) If one happens, know what to do and who should do it.
- 3) Always have at least two people who know what to do and when.
- 4) Improve future preparedness by learning from experience.

POSSIBLE “EMERGENCIES”	QUESTIONS / ISSUES
<ul style="list-style-type: none"> <li>* Electricity power cut               <ul style="list-style-type: none"> <li>- for short length of time</li> <li>- for a long length of time</li> </ul> </li> </ul>	<ul style="list-style-type: none"> <li>* What type of refrigerator/freezer?</li> <li>* How many hours protection can each type give?</li> <li>* When and where to move vaccines?</li> <li>* Need and availability of icepacks/cold boxes?</li> </ul>
<ul style="list-style-type: none"> <li>* Refrigerator breakdown               <ul style="list-style-type: none"> <li>- minor repairs needed</li> <li>- serious repairs needed</li> </ul> </li> </ul>	<ul style="list-style-type: none"> <li>* Location of other vaccine storage equipment?</li> <li>* Checklist for initial diagnosis? (See Section 8.1)</li> </ul>
<ul style="list-style-type: none"> <li>* Delay in vaccine arrival</li> </ul>	<ul style="list-style-type: none"> <li>* Reserve stocks?               <ul style="list-style-type: none"> <li>- at your facility?</li> <li>- at higher level?</li> <li>- elsewhere in your area?</li> </ul> </li> <li>* Planned rescheduling of immunization?</li> </ul>
<ul style="list-style-type: none"> <li>* Transport breakdown</li> </ul>	<ul style="list-style-type: none"> <li>* How long is “cold life” of boxes?</li> <li>* Alternative refrigerator storage or ice supply along the route?</li> </ul>
<ul style="list-style-type: none"> <li>* Loss of vaccine potency (cold chain failure)</li> </ul>	<ul style="list-style-type: none"> <li>* Reserve stocks at higher level?</li> <li>* Temperature records/monitor cards to help investigation?</li> </ul>
<ul style="list-style-type: none"> <li>* Epidemic - sudden need for control immunization</li> </ul>	<ul style="list-style-type: none"> <li>* Reserve stocks at your facility or higher level               <ul style="list-style-type: none"> <li>- of vaccine?</li> <li>- of syringes &amp; needles?</li> </ul> </li> <li>* Sufficient refrigerator capacity, cold boxes and icepacks?</li> <li>* Transport and fuel available?</li> </ul>
<ul style="list-style-type: none"> <li>* AEFI</li> </ul>	<ul style="list-style-type: none"> <li>* Investigation forms? (Annex 5)</li> <li>* Procedures for handling suspect vaccine?</li> </ul>

---

## B. Specific aspects of emergency plan for polio NIDs

Each location which stores vaccines, but particularly Oblast SESs and Rayon/City SESs should have its own written emergency plan.

Each local plan should include the following information:

1. How many hours each type of refrigerator or freezer can keep a safe temperature if electricity fails, assuming it is not opened meanwhile. This will vary according to the season of the year, of course, but guideline figures for the hottest season are as follows:

<u>Oblast SES:</u>	Large horizontal refrigerator (MK 302)* (* assuming that full set of water packs installed inside)	48 hours
	Large horizontal freezer (HF 5506)	20 hours
	Medium horizontal freezer (SB 300)	20 hours

Rayon SES/Polyclinic: Vertical household refrigerator 2-3 hours

A cool and well ventilated room for the equipment is best.

2. Who keeps a spare key for the vaccine store room, and is responsible in case the designated cold chain person is absent?

3. The location of the nearest suitable refrigerators/freezers to be used if vaccines have to be moved, and the name and telephone number of the contact person if it is in another building or institution.

4. The number and type of cold boxes to be kept available in case vaccines have to be moved, and the minimum number of frozen icepacks always to be available to put in the cold box(es).

Note: Cold Chain Monitor Cards stored with the vaccine, must be moved with the vaccine if the vaccine is moved to another refrigerator or freezer or to a cold box, even if temporarily, and the top part of the card filled in accordingly.

5. The length of time that a cold box can keep vaccines at a safe temperature (below +10 degrees C) without changing ice or icepacks and without opening it (the "cold life" of the box.) This also depends on outside temperature and of course on the number of frozen icepacks and the thickness of the insulated wall of the box. Guideline figures for the hottest time of year are as follows:

- Large red cold box ("Igloo" 20 litres vaccine capacity):
  - with maximum number of frozen icepacks (30) : 84 hours
- Small red cold box ("Igloo 4.5 litres vaccine capacity):
  - with maximum number of frozen icepacks (9) : 50 hours
- Local (Russian) cold bag: (4 litres vaccine capacity)
  - cold life not tested

6. The location of a reserve drum/container of gasoline in case urgently needed.



# Annex 1: Vial size and doses/vial for EPI vaccines

<b>OPV</b>	Foreign vaccine* (10 and 20 dose vials)	2 drops/dose
	Russian vaccine (50 dose/5ml vials)	2 drops/dose
	Russian vaccine (25 dose/5ml vials)	4 drops/dose
	Russian vaccine (10 dose/2ml vials)	2 drops/dose
<b>MEASLES</b>	Foreign vaccine (10 dose vials)	0.5 ml/dose
	Russian vaccine (10 dose vials)	0.5 ml/dose
	Russian vaccine (5 dose vials)	0.5 ml/dose
	Russian vaccine (1 dose vials)	0.5 ml/dose
<b>DPT</b>	Foreign vaccine (10 and 20 dose vials)	0.5 ml/dose
	Russian vaccine (20 dose vials)	0.5 ml/dose
	Russian vaccine (3 dose vials)	0.5 ml/dose
	Russian vaccine (1 dose vials)	0.5 ml/dose
<b>BCG (Infants &lt; 1yr)</b>	Foreign vaccine (20 dose ampoules)	0.05 ml/dose
	Russian vaccine (10 & 20 dose ampoules)	0.1 ml/dose
<b>BCG (Children &gt; 1yr)</b>	Foreign vaccine (20 dose ampoules)	0.1 ml/dose
	Russian vaccine (10 & 20 dose ampoules)	0.1 ml/dose
<b>BCG – m</b>	Russian vaccine (10 & 20 dose ampoules)	0.1 ml/dose
<b>HEPATITIS B VACCINE</b>		
	Foreign vaccine (10 and 20 dose vials)	0.5 ml/dose
	Foreign vaccine (1 dose vials)	1.0 ml/dose
	Russian vaccine (20 dose vials)	0.5 ml/dose
<b>MUMPS VACCINE</b>		
	Foreign vaccine (10 and 20 dose vials)	0.5 ml/dose
	Russian vaccine (20 dose vials)	0.5 ml/dose

\* Foreign vaccines used in immunization programmes are usually supplied in 10 or 20 dose vials. However, foreign vaccine manufacturers can also provide almost any vial size ordered.

# Annex 2: Vaccine stock record

Store Name: \_\_\_\_\_ Vaccine: \_\_\_\_\_ Vial Size: \_\_\_\_\_

Region: \_\_\_\_\_ Province: \_\_\_\_\_ District: \_\_\_\_\_

Date	From: Manufacturer/ Supplier	To: Store/ Health Unit	Batch Number	Expiry Date	Vaccine Quantities			Remarks
					Received (doses)	Issued (doses)	Balance (doses)	
-	-	-	Carried	forward	from	previous	sheet	-
				<b>Totals:</b>				
				<b>Physical</b>	<b>Stock</b>	<b>Check:</b>		
					<b>Carried Forward:</b>			

# Annex 3: Vaccine arrival report

## FLIGHT DETAILS:

AIRPORT INFORMATION		DATE AND TIME		Flight No.
		Arrival	Departure	
ORIGIN				
STOPOVER				
FINAL				
SUPPLIER				

## VACCINES:

VACCINE	MANUFACTURER	NUMBER OF VIALS	DOSES PER VIAL	LOT NUMBER	EXPIRY DATE

## DILUENT:

VACCINE	MANUFACTURER	NUMBER OF VIALS	DOSES PER VIAL	LOT NUMBER	EXPIRY DATE

ARE VIAL MONITORS ATTACHED?	YES	NO
-----------------------------	-----	----

IS AIRWAY BILL ATTACHED?	YES	NO
IS PACKING LIST ATTACHED?	YES	NO

## SHIPPING PROCEDURES:

WAS ADVANCE FAX RECEIVED? (DATE?)	
WAS IT SENT TO THE CORRECT ADDRESS?	
WHO WAS IT SENT BY?	
WERE THERE DIFFERENCES BETWEEN THE FAXED INFORMATION AND THE ACTUAL ARRIVAL? WHAT?	

## COLD CHAIN MONITOR:

HOW MANY IN EACH BOX?				
VACCINE				
INDEX	A B C D	A B C D	A B C D	A B C D
DATE OF PACKING				
DATE OF ARRIVAL				

**DPT,DT,Td, AND TT SHIPPING INDICATORS:**

WERE THE TT SHIPPING INDICATORS INCLUDED?	YES	NO
WAS THE DOT BLACK ?	YES	NO

**VACCINE TRANSPORT BOXES:**

TOTAL NUMBER OF BOXES?	
------------------------	--

IS THE CARGO PROPERLY LABELLED?	YES	NO
---------------------------------	-----	----

IS THE TELEPHONE NUMBER OF THE CONSIGNEE ON THE CARGO?	YES	NO
--	-----	----

DOES THE LABEL STATE " STORE VACCINES AT 0°C TO 8°C"?	YES	NO
---	-----	----

DOES THE LABEL STATE " DO NOT FREEZE"? (IF DPT, DT, Td, or TT VACCINES)	YES	NO
---	-----	----

WERE THE PACKAGES LABELLED "VACCINE RUSH"?	YES	NO
--	-----	----

WERE THE PACKAGES LABELLED "CONTAINS VACCINE"?	YES	NO
--	-----	----

**WHAT WAS THE STATE OF THE PACKAGE ON ARRIVAL?**

--

Name:	Date:	Signature:
-------	-------	------------

# Annex 4A: Monthly temperature recording sheet (sample)

Name of facility:.....  
 Type of equipment: .....  
 Date: .....  
 Signature: .....

Date	1	2	3	4	5	6	7	8	9	10	11	12	13	14		
Temp	M	A	M	A	M	A	M	A	M	A	M	A	M	A	M	A
20																
18																
16																
14																
12																
10																
8																
6																
4																
2																
0																
-2																
-4																
-6																
-8																
-10																
-12																
-14																
-16																
-18																
-20																
-22																
-24																
-26																

SAFE ZONE FOR ALL VACCINES

SAFE ZONE FOR POLIO, MEASLES AND MUMPS

---

# Annex 4B: Annual temperature recording sheet (sample)

Headings: facility, refrigerator etc.

Month	1	2	3	4	5	6	7	8	9	etc														
J																								
a																								
F																								
a																								
M																								
a																								
A																								
M																								
J																								
J																								
A																								
S																								
O																								
N																								
D																								

---

# Annex 5A: Adverse events following immunization

## Causes related to practice

(from WHO investigations in various countries, reported in *Weekly Epidemiological Record* no. 32, August 1996)

- Too much vaccine given in one dose
- Improper immunization site or route
- Syringes and needles improperly sterilized
- Vaccine reconstituted with incorrect diluent
- Wrong amount of diluent used
- Drug substituted for vaccine or diluent
- Vaccine prepared incorrectly for use
- Vaccine or diluent contaminated
- Vaccine stored incorrectly
- Contraindications ignored
- Reconstituted vaccines not discarded at end of immunization session, and used at subsequent one

---

# Annex 5B: AEFI case-investigation report form

(from Appendix D, pages 39-40, *Surveillance of Adverse Events Following Immunization: Field Guide for Managers of Immunization Programmes*, WHO/EPI/TRAM/93.2)

The health worker who detects an AEFI should begin filling in this form. The health worker (or workers) who conducts the investigation and analyses the data should then complete the report.

**I. Patient ID No.** \_\_\_\_\_

1. Date of Birth (DD MM YY): \_\_\_\_\_ 2. Sex: \_\_\_\_\_

3. Family name: \_\_\_\_\_ 4. First name: \_\_\_\_\_

5. Parents' names: \_\_\_\_\_

6. Address: \_\_\_\_\_

\_\_\_\_\_

## II. Immunization History

1. Date of immunization (DD MM YY): \_\_\_\_\_

2. Names and dose numbers of vaccines given that day to this patient:

\_\_\_\_\_

\_\_\_\_\_

3. Manufacturer and lot numbers of suspect vaccine or vaccines:

\_\_\_\_\_

\_\_\_\_\_

Explain how these were identified: \_\_\_\_\_

\_\_\_\_\_

4. Immunization facility:

\_\_\_\_\_

5. Name of vaccinator:

\_\_\_\_\_

6. Observations on storage and handling of other vaccines in stock: \_\_\_\_\_

\_\_\_\_\_



---

### III. Medical Incident

1. Symptoms, with date and time of onset of each: \_\_\_\_\_

\_\_\_\_\_

2. Laboratory findings: \_\_\_\_\_

\_\_\_\_\_

3. History of reactions to previous doses, drug allergies, etc: \_\_\_\_\_

\_\_\_\_\_

4. Treatment and outcome: \_\_\_\_\_

\_\_\_\_\_

### IV. Summary of Event

State whether this event was part of a cluster or was a single occurrence and explain why you think so:

\_\_\_\_\_

\_\_\_\_\_

(Note: If this AEFI was part of a cluster, the Event Description Report will provide detailed information about the cluster (see Chapter 4 of the Field Guide)

Investigated by: \_\_\_\_\_

Date (DD MM YY): \_\_\_\_\_

\_\_\_\_\_

---

# Annex 6: National immunization days and mass campaigns

## Some points for special attention

The procedures for safe handling of vaccines and use of equipment to ensure that potent vaccine is always administered are equally important for special activities such as National Immunization Days (NIDs) or mass campaigns. For such activities, however, remember these additional points:

- Much larger quantities of vaccine are distributed at one time, so more cold boxes and vaccine carriers are needed. Extra Cold Chain Monitor Cards may also be needed.
- The most important need for a polio NID, after the vaccine itself, is extra icepacks and ice. For a mass campaign for diphtheria or other injectable vaccine, it is sufficient syringes/needles and trained vaccinators.
- The vaccine should be distributed from a central vaccine store not long before the NID or mass campaign, so that it does not need to be stored at any one place for long. At region and health clinic levels, cold boxes with icepacks can provide temporary storage if refrigerator capacity is insufficient.
- For a mass campaign with diphtheria or other adsorbed vaccine, particular care should be taken to avoid accidentally freezing vaccine during bulk distribution. Carefully calculate what number of icepacks needed, pack the vaccine well protected and use “Freeze watch” indicators in cold boxes as well as Cold Chain Monitor Cards.
- Records of quantity of vaccine received, distributed, used and any remaining afterwards should be kept separately from vaccine records for the routine immunization programme (or separate entries made in the vaccine registers).
- If vaccine is received from an unfamiliar manufacturer for an NID, check to make sure about the instructions for dosage (number of drops per dose for OPV)
- At the end of each round of an NID or mass campaign, return any unused vaccine to safe storage at the Region or Oblast SES and separately account for it.
- After a mass campaign using an injectable vaccine, control and safe disposal and destruction of used disposable syringes is particularly important as the quantities will be very large.

*Detailed guidance on planning the logistic support for National Immunization Days is given in the WHO “Field Guide for Supplementary Activities Aimed at Achieving Polio Eradication”.*

# Annex 7: Sample refrigerator/ cold chain check list

Name of health facility/vaccine store: \_\_\_\_\_ Date: \_\_\_\_\_

Indicator	YES	NO
1. Refrigerators/freezers correctly situated?		
2. Room cool and properly ventilated?		
3. Working thermometer in each refrigerator/freezer?		
4 Refrigerator temperature in correct range?		
5. Freezer (if used) temperature in correct range?		
6. Temperature record sheet(s) correct and up to date?		
7. All vaccines in stock and suitable quantities?		
8. All vaccines correctly stored?		
9. BCG/measles diluent stored beside its vaccine?		
10. Vaccine stock record books correct and up to date?		
11. Vaccine stock record book includes diluent stock?		
12. OPV Vial Monitors all unchanged?		
13. Cold Chain Monitor Cards (if used) all white?		
14. Cold Chain Monitor Cards (if used) correctly filled in?		
15. Sufficient frozen icepacks in freezer?		
16. (Household refrigerator) Water containers in bottom?		
17. (if observed) Cold box/vaccine carrier correctly loaded with vaccine and icepacks?		
18. (if observed) Vaccines correctly handled during immunization session?		
19. Sufficient stock of syringes and needles?		
20. Used syringes and needles discarded safely?		
21. Same quantity used syringes as injectable imms. given today?		
22. (if seen used) Steam sterilizer properly used?		
Total YES and NO		

Where to use check list: immunization rooms, rayon/etrap SES, oblast/velayet SES

When to use: during supervisory visits, according to a planned schedule (selected locations, monthly and/or quarterly)

The results of checks made at various health facilities and SESs should be summarized and analyzed on the basis of the percentage of “YES” answers. For any “NO” answers, use space overleaf to give detail if necessary. Analysis of “NO” answers should be used to plan for remedial/refresher training and to plan for future supervisory visits.

---

# Annex 8: List of related documents available in Russian

(as of December 1997)

1. WHO/EPI, Geneva. "Immunization in Practice", WHO/EPI/PHW/84.01 to 84.07 Rev.1.
2. WHO/EPI, Geneva. "The use of opened vials of vaccine in subsequent immunization sessions - WHO Policy Statement" WHO/EPI/LHIS/95.01
3. WHO/EPI, Geneva. "Vaccine Vial Monitor and Opened Vial Policy - Questions and Answers" WHO/EPI/LHIS/96.01
4. WHO/EPI, Geneva. "Vaccine Vial Monitor - Training Guidelines" WHO/EPI/LHIS/96.04
5. WHO/EPI, Geneva. "Safety of injections in immunization programmes - WHO recommended policy" WHO/EPI/LHIS/96.05
6. WHO/EPI, Geneva. "Reducing the risk of unsafe injections in immunization programmes - the role of injection equipment" WHO/EPI/LHIS/94.2 (adapted version)
7. WHO/EPI Geneva. "Surveillance of Adverse Events following Immunizations: Field Guide for managers of immunization programmes" WHO/EPI/TRAM/93.2 Rev. 1
8. WHO/EPI Geneva. "Field Guide for Supplementary Activities Aimed at Achieving Polio Eradication" (1995) WHO/EPI/GEN/95.01; updated version (1997): WHO/EPI/GEN/95.01 Corr.1
9. USAID/BASICS. "Some Notes on Storage Temperatures, Stability and Handling of Oral Polio Vaccine." (Russian/English, 1 page).
10. WHO/EPI, Geneva. Galazka, A. "Stability of Vaccines." WHO/EPI/GEN/89.8. (Russian, 63 pages; English, 57 pages).
11. Litvinov, S. K., V. M. Bolotosky, Y. V. Kocenka. "Cold Chain: Its Role and Meaning in the Struggle Against Infection." *Zh. Mikrobiol Epidemiol Immunobiol.* 1989. (11): 88-95. (Russian only, 8 pages – contact USAID/BASICS).
12. USAID/REACH/John Snow, Inc. "List of Contents of WHO Cold Chain Technicians' Tool Kit." 1993. (Russian, 2 pages; English, 2 pages – contact USAID/BASICS).
13. WHO/EPI, Geneva. "Effects of Freezing on the Appearance, Potency and Toxicity of Absorbed and Unabsorbed DPT Vaccines." *Weekly Epidemiological Record.* December 12, 1980. (no. 50). (Russian, 14 pages; English, 6 pages).
14. WHO/EPI, Geneva. "Expanded Programme on Immunization: Stability of Vaccines." *Weekly Epidemiological Record.* No. 30. July 27, 1990. pp. 233-35. (Russian, 5 pages; English, 3 pages).

- 
15. WHO/EPI, Geneva. "Guidelines on the International Packaging and Shipping of Vaccines." EPI/CCIS/81.4. REV. 5. (Russian, 3 pages; English, 2 pages).
  16. WHO/EPI, Geneva. "Stability of Oral Polio Vaccine After Repeated Freezing and Thawing." *Weekly Epidemiological Record*. July 6, 1990. (No. 27). (Russian, 9 pages; English, 6 pages).
  17. WHO/EPI, Geneva. "Technicians' Handbooks for Compression Refrigerators."  
"Handbook A: Servicing and Repair Techniques." (Russian only, 99 pages).  
"Handbook B: Faults and Fault-Finding." (Russian only, 30 pages).  
"Handbook C: Repair Work." (Russian only, 45 pages).  
"Handbook D: Task Sheets and Progress Tests." (Russian only, 53 pages).  
(Direct unadapted translation from the WHO Training Course).
  18. WHO/EPI, Geneva. "Textbook for Slideset 'Sterilization and Sterile Procedures'." (slide set not included). (Russian, 7 pages; English, 8 pages).
  19. WHO/EPI, Geneva. "Training Materials on Steam Sterilization." (Russian only, 12 pages -- adapted from Immunization in Practice Training Course, WHO, Geneva).
  20. WHO/EPI, Geneva. "The Cold Chain" (Cartoon), 6 minute video, VHS, WHO/CCV/03